



GEEPLUS

VM2618 & VM2836

P_{100} is the continuous (100% ED) excitation power at which the coil attains temperature T_{max} with the part mounted to a massive heatsink at 20°C

P_{100} 8 W
 T_{max} 130 °C

Total Mass 60 g
 Coil Mass 6 g

Model No.	Resistance R_{20}	Inductance	Force Constant	Velocity Constant	Current I_{100}
VM2xxx-180	9.6 Ω	1.3 mH	4 N/A	4 Vs/m	771 mA
VM2xxx-132	34.4 Ω	5.3 mH	8 N/A	8 Vs/m	407 mA
VM2xxx-112	55.0 Ω	7.3 mH	9 N/A	9 Vs/m	322 mA
VM2xxx-080	286.0 Ω	40.0 mH	21 N/A	21 Vs/m	141 mA

	Max 'ON' time	Peak Force
100% ED	∞	3.4 N
50% ED	55 s	4.8 N
25% ED	12 s	7.0 N
10% ED	3 s	10.6 N

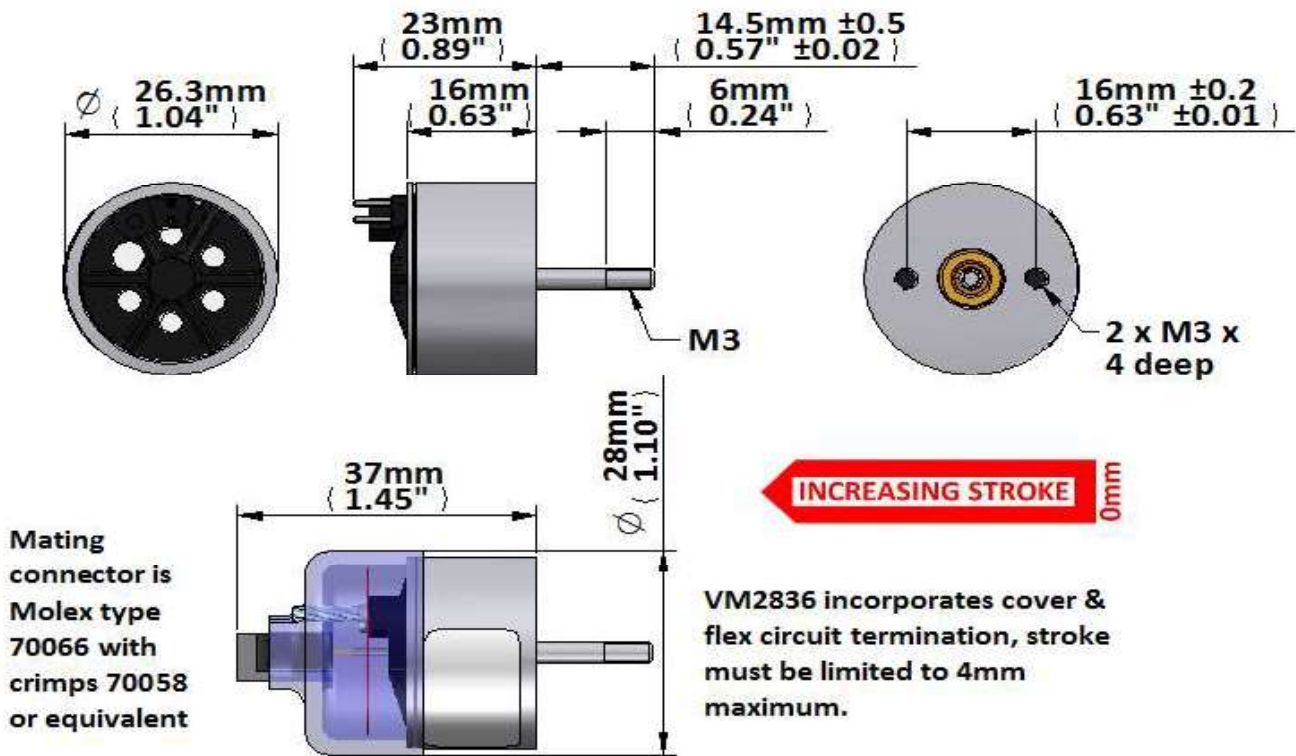

Force (N) vs Displacement (mm)

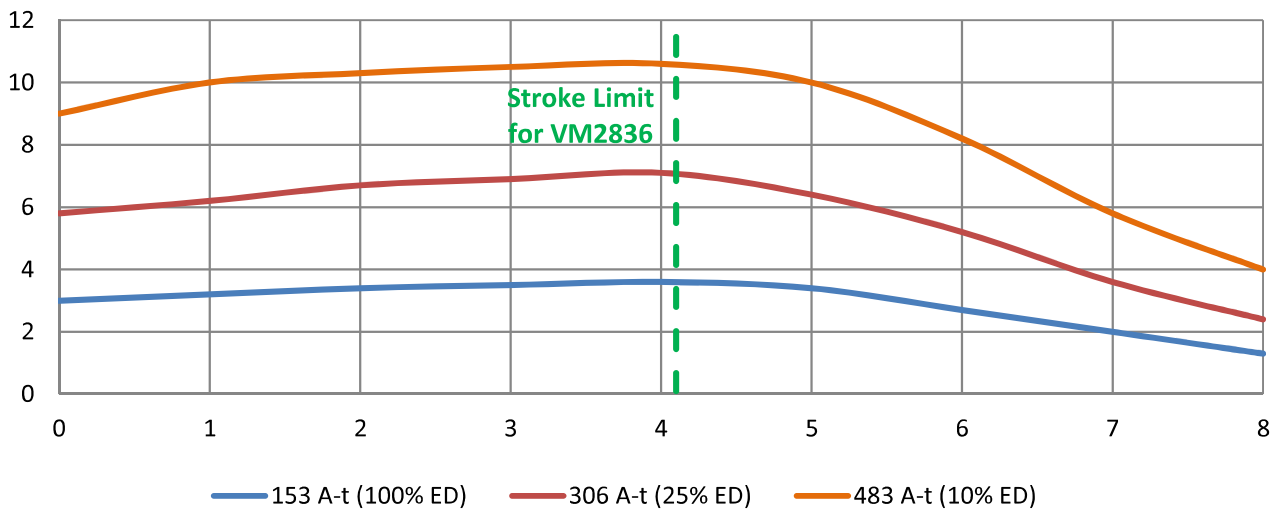

Geeplus reserves the right to change specifications without notice
www.geeplus.com