

CURRENTLY AVAILABLE CATALOG OPTIONS
CATALOG CODE
EC15-CW-6mm-24
EC15-CCW-6mm-24
EC15-CW-1/4-24
EC15-CCW-1/4-24
EC15-CW-6mm-12
EC15-CCW-6mm-12
EC15-CW-1/4-12
EC15-CCW-1/4-12
EC15-CW-6mm-24-L
EC15-CCW-6mm-24-L
EC15-CW-1/4-24-L
EC15-CCW-1/4-24-L
EC15-CW-6mm-12-L
EC15-CCW-6mm-12-L
EC15-CW-1/4-12-L
EC15-CCW-1/4-12-L

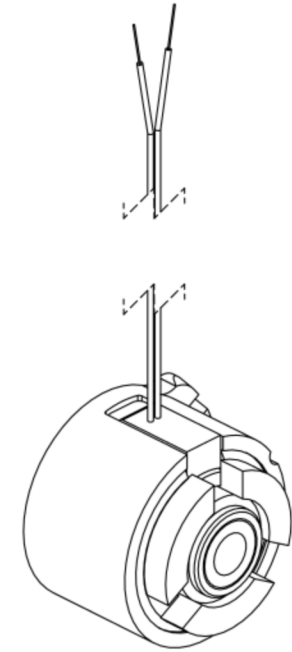
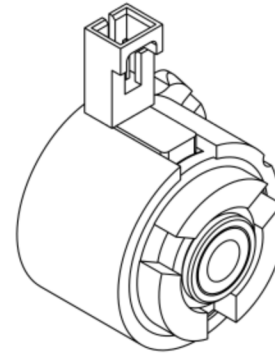

CATALOG CODE EC15-XX-XXX-XX-X

DIRECTION
CW CCW

SHAFT ID
6mm 1/4 (IN)

VOLTAGE
12 24

OTHER OPTIONS
(Blank) - MOLDED COIL CONNECTOR L - FLYING LEADS

LEVEL	DESCRIPTION	DRAWN	DATE	APPROVED
DRAWN:	DMT	DATE:	11-10-86	
CHECKED:	HMA	DATE:	09-10-87	
APPROVED:	GDL	DATE:	09-11-87	
REVISED:	06-03-20	DIMS:	[IN]mm	

SALES DRAWING

DESCRIPTION: **EC15** REV: **R**

SCALE: 1:1 DO NOT SCALE DRAWING SHEET 1 OF 3

INTERPRET PRINT PER
ASME Y14.5M-1994
THIS PRINT IS THE
CONFIDENTIAL PROPERTY
OF REELL PRECISION MFG.
THIRD ANGLE PROJECTION



REELL PRECISION MANUFACTURING
1259 WILLOW LAKE BOULEVARD
SAINT PAUL, MINNESOTA 55110-5103, USA

SPECIFICATIONS SUBJECT TO CHANGE

REELL RADIAL ELECTRIC CLUTCH

SHAFT NOM. I.D.	CROSS PIN SIZE	ONE MILLION CYCLE TORQUE RATING: [15 Lb-in] 1.7 Nm TOTAL LOAD.
6mm	2.5mm	6mm BORE MOLDED COIL CONNECTOR SHOWN
1/4 IN	3/32 IN	

NOTES:

- CONNECTOR PINS ARE [.025 x .025] 0.64 x 0.64 SQUARE. THE FOLLOWING MATING CONNECTORS CAN BE USED.
 TERMINAL: POLARIZED LATCHING CONNECTOR, INSULATION DISPLACEMENT CONTACTS
 AMP NO. 5-103956-1
 ALTERNATE TERMINAL:
 MOLEX NO. 14-60-0022
 A LEAD SET WITH MATING CONNECTOR AND [15 INCH] 380mm LEADS IS AVAILABLE. REELL CATALOG CODE LS-01-380.
- RESISTANCE: 12 VOLTS 60 OHMS AT [68°F] 20°C.
 24 VOLTS 227 OHMS AT [68°F] 20°C.

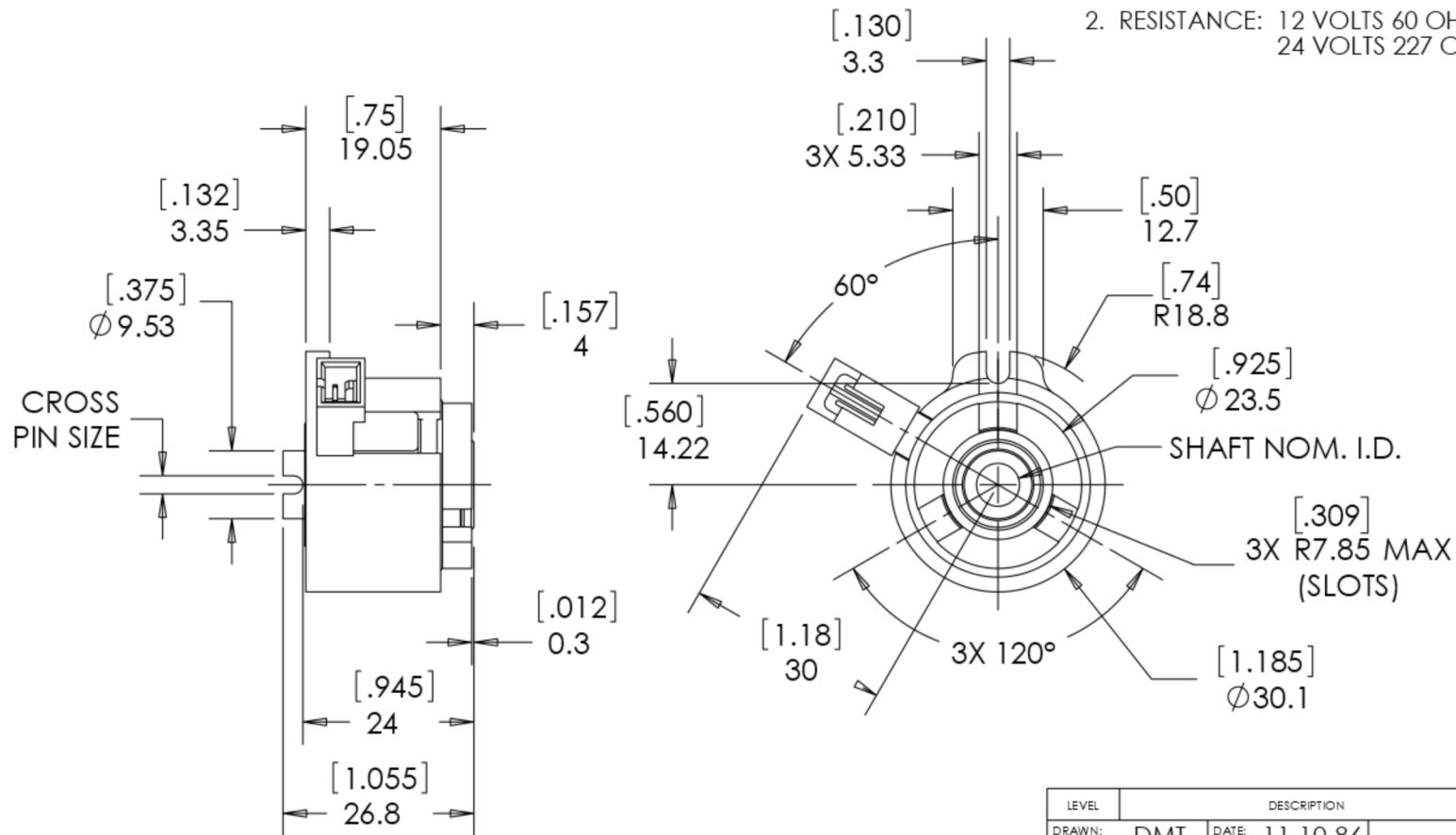

ALL DIMENSIONS REFERENCE
SEE CAD MODEL FOR UNSPECIFIED FEATURES.

SPECIFICATIONS SUBJECT TO CHANGE

INTERPRET PRINT PER
ASME Y14.5M-1994
THIS PRINT IS THE
CONFIDENTIAL PROPERTY
OF REELL PRECISION MFG.

THIRD ANGLE PROJECTION

LEVEL	DESCRIPTION	DRAWN	DATE	APPROVED
DRAWN:	DMT	DATE:	11-10-86	
CHECKED:	HMA	DATE:	09-10-87	
APPROVED:	GDL	DATE:	09-11-87	
REVISED:	06-03-20	DIMS:	[IN]mm	

TITLE:	
SALES DRAWING	
DESCRIPTION:	REV:
EC15	R
SCALE: 1:1	DO NOT SCALE DRAWING
SHEET 2 OF 3	



REELL PRECISION MANUFACTURING
1259 WILLOW LAKE BOULEVARD
SAINT PAUL, MINNESOTA 55110-5103, USA

8 7 6 5 4 3 2 1

NOTES:

- LEADS - [8 INCH] 200mm NO. 24 AWG STRANDED WIRE-CROSS LINKED POLYETHYLENE INSULATION [.011] 0.28 THICK. UL 3265 & CSA AWM APPROVED. RATED FOR 150 V & 125°C.

FLYING LEAD OPTION:

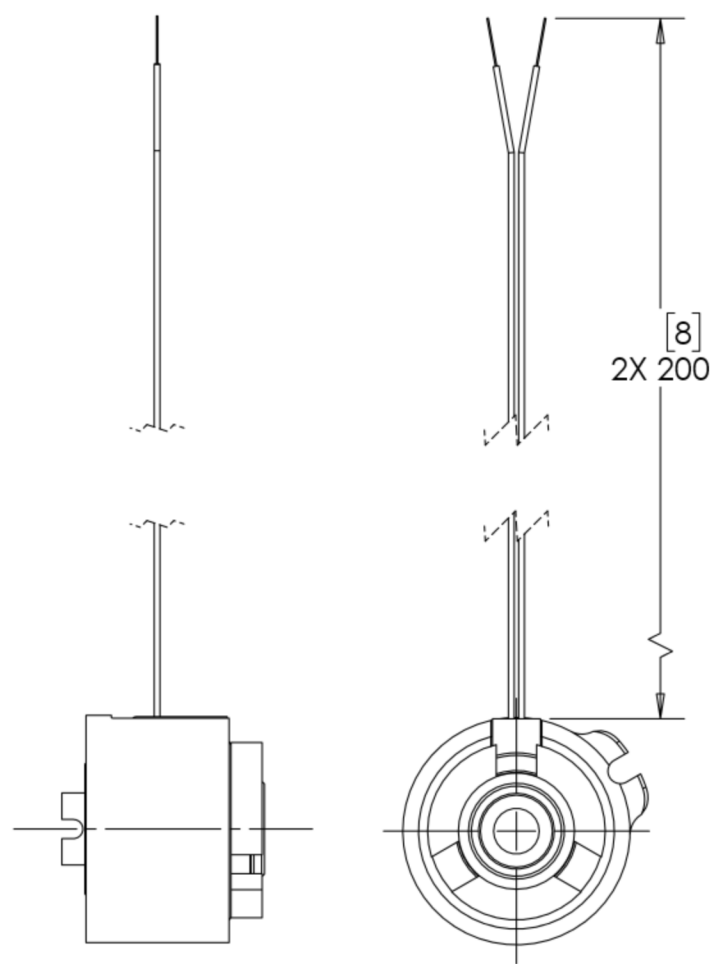



ALL DIMENSIONS REFERENCE
SEE CAD MODEL FOR UNSPECIFIED FEATURES.

SPECIFICATIONS SUBJECT TO CHANGE

INTERPRET PRINT PER
ASME Y14.5M-1994
THIS PRINT IS THE
CONFIDENTIAL PROPERTY
OF REELL PRECISION MFG.

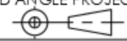
THIRD ANGLE PROJECTION



LEVEL	DESCRIPTION		DRAWN	DATE	APPROVED
DRAWN:	DMT	DATE:	11-10-86		
CHECKED:	HMA	DATE:	09-10-87		
APPROVED:	GDL	DATE:	09-11-87	TITLE:	
REVISED:	06-03-20	DIMS:	[IN]mm	SALES DRAWING	
 REELL PRECISION MANUFACTURING 1259 WILLOW LAKE BOULEVARD SAINT PAUL, MINNESOTA 55110-5103, USA			DESCRIPTION:		REV:
			EC15		R
SCALE: 1:1		DO NOT SCALE DRAWING		SHEET 3 OF 3	

8 7 6 5 4 3 2 1