

CATALOG CODE
SA-X.X-XX-XXX

TORQUE Nm
0.2
0.4
0.8
0.95

DIRECTION
CW
CCW

BORE (SHAFT INTERFACE)
6mm
1/4 (IN)
8mm

SHAFT NOM. ID
6mm
1/4"
8mm

DYNAMIC TORQUE
0.2 ± 0.04 Nm [1.77 ± 0.355 LB-IN]
0.4 ± 0.08 Nm [3.54 ± 0.709 LB-IN]
0.8 ± 0.16 Nm [7.08 ± 1.417 LB-IN]
0.95 ± 0.19 Nm [8.41 ± 1.684 LB-IN]

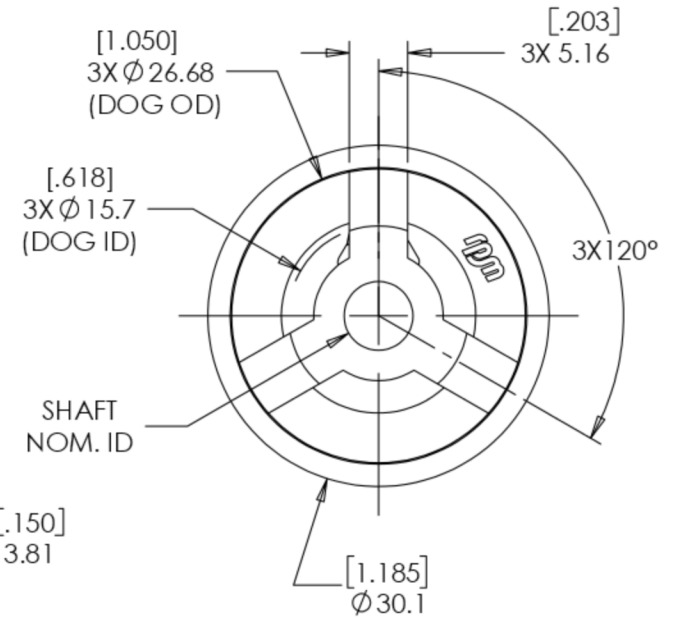
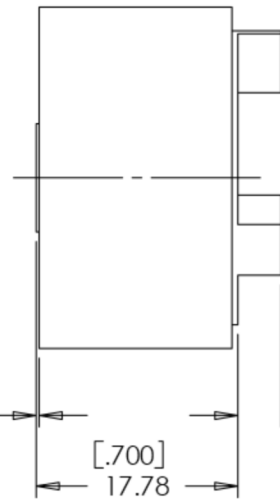
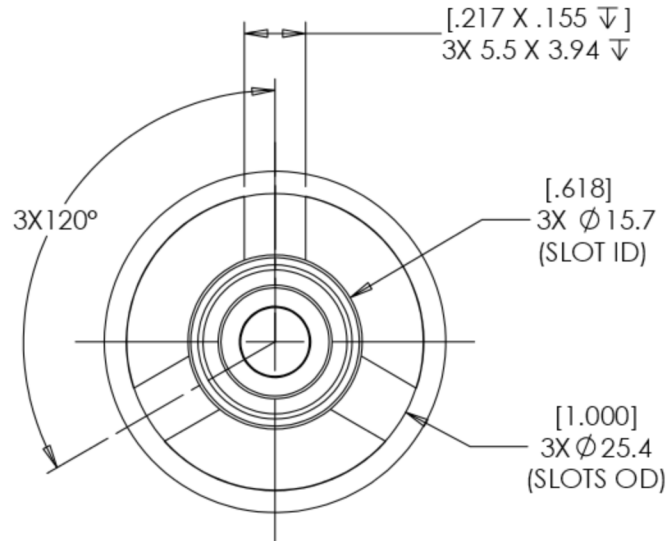

ALL DIMENSIONS REFERENCE
SEE CAD MODEL FOR
UNSPECIFIED FEATURES

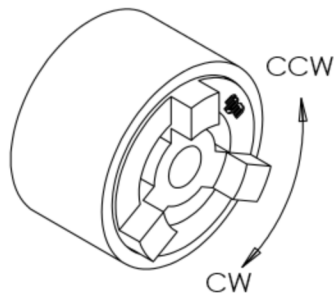

SHAFT INPUT

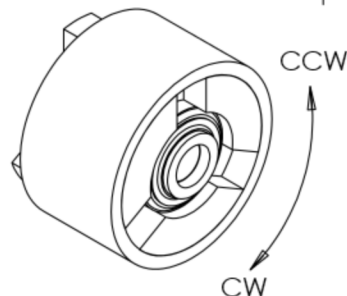

HOUSING INPUT

SPECIFICATIONS SUBJECT TO CHANGE

	ECO NO: 02641	PART LIFECYCLE: RELEASED
	APPROVED BY: BOB WAHLSTEDT	DEVELOPMENT CYCLE: PRODUCTION
	APPROVED DATE: 18MAY20	DESCRIPTION:
	PROJECT NO: 0	SALES DRAWING
REELL PRECISION MANUFACTURING 1259 WILLOW LAKE BOULEVARD SAINT PAUL, MINNESOTA 55110-5103, USA	ENGINEER: BOB WAHLSTEDT	PART NO: SA
THIS PRINT IS THE CONFIDENTIAL PROPERTY OF REELL PRECISION MFG.	DRAWN BY: DERICK OFFOR	
INTERPRET PRINT PER ASME Y14.5M-2009	THIRD ANGLE PROJECTION 	SCALE: 1.5:1
	DIMENSIONS: mm [IN]	DO NOT SCALE DRAWING
		SHEET 1 OF 1