

The Printed Motor Works GPN16 is a totally enclosed dc motor in an ultra slim pancake profile. This pancake motor can provide a cost effective servo capability either direct drive or combined with a timing pulley/gearbox.

Features & Benefits

- Ultra slim profile
- Minimum torque ripple
- Very low inertia
- High peak torques
- Zero cogging
- Ultra slow/creep capability
- Low inductance
- EMC compatible

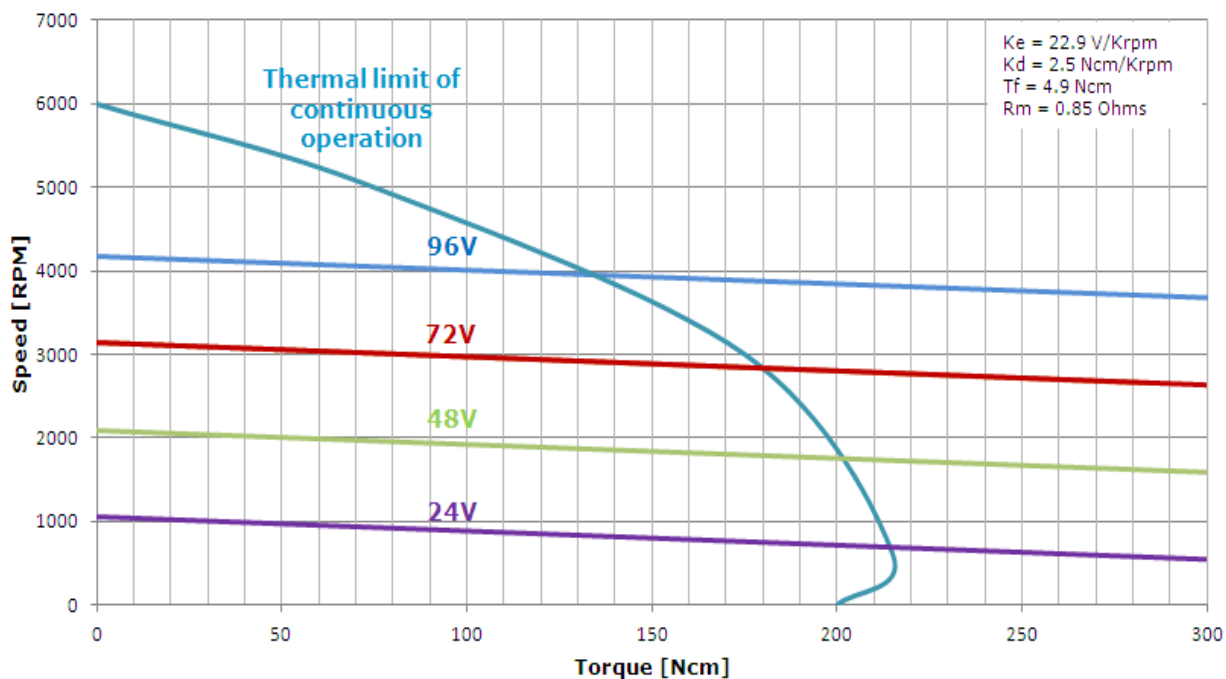
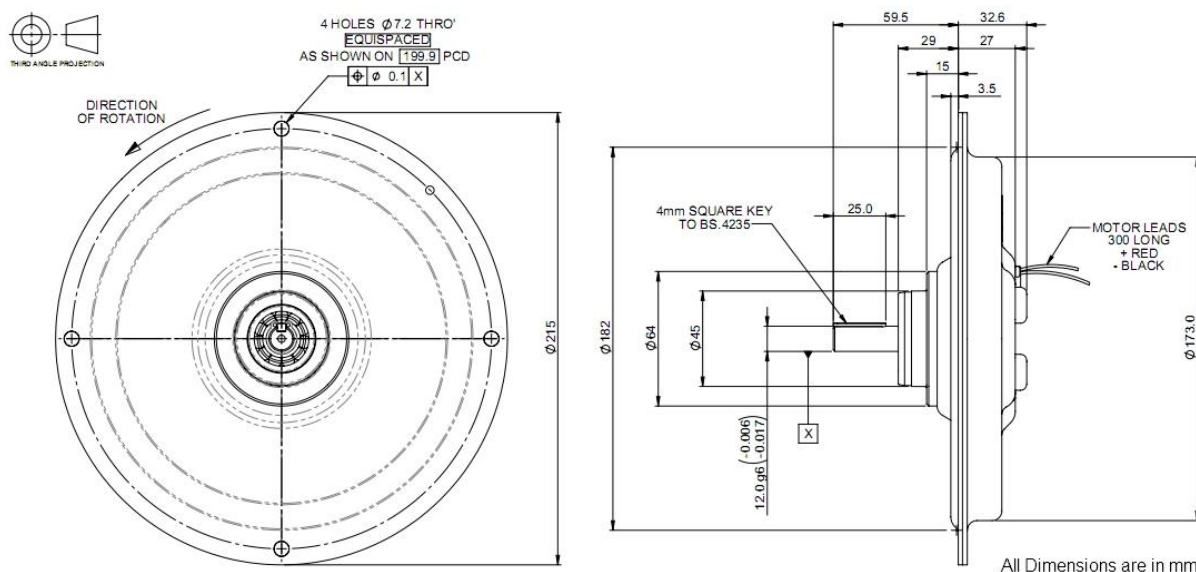
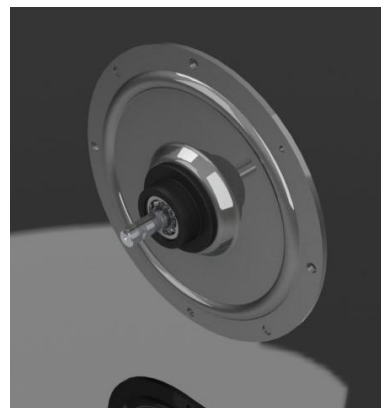

NOTE: The above voltages are examples, not a predefined maximum or minimum. Due to ongoing product improvements data is subject to change without notice.

Applications: Servo mechanisms, motion control, industrial robots, CNC machining, printing machinery, logistics solutions, medical mobility, medical scanners, flight simulators, marine autopilots and high ambient temperature ventilation.

Markets: Industrial automation, automotive, medical, life sciences, aerospace, printing, logistics, instrumentation, test and measurement, oil & gas and offshore marine.

Design Modifications

- Encoders
- Timing pulleys
- Long leads
- Tri-rated cable
- Open/kit option
- Customised shafts
- EMC suppression
- Connectors
- Rated for operation in 150°C ambient
- Mounting customisation

Performance Specifications	Symbol	Units	GPN16
Peak Torque	Tp	N-cm (oz-in)	1700 (2407.7)
Rated Speed	N	RPM	3000
Rated Continuous Torque @ 25°C	T ₂₅	N-cm (oz-in)	170 (240.7)
Rated Power Output	P	Watts	533
Maximum Recommended Speed	Nmax	RPM	6000
Continuous Stall Torque	Ts	N-cm (oz-in)	119.76 (169.6)
Cogging Torque	Tc	N-cm (oz-in)	0 (0)
Electrical Specifications			
Rated Terminal Voltage	E	Volts	75.8
Rated Continuous Current	I	Amps	8.4
Peak Current	Ip	Amps	77.96
Continuous Stall Current	Is	Amps	5.7
Winding Specifications			
Terminal Resistance ± 10%	Rm	Ohms	0.85
Armature Resistance ± 10%	Ra	Ohms	0.78
Back EMF Constant ± 5%	Ke	V/kRPM	22.9
Torque Constant ± 5%	Kt	N-cm/Amp (oz-in/Amp)	21.87 (30.97)
Viscous Damping Constant	Kd	N-cm/KRPM (oz-in/KRPM)	2.5 (3.54)
Armature Inductance	L	µH	<0.03
Temperature Coefficient of KE	C	%/°C Rise	-0.19
Number of Commutation Bars	Z		165
Mechanical Specifications			
Moment of Inertia	Jm	Kg-cm ² (oz-in-sec ²)	6.284 (0.089)
Average Friction Torque	Tf	N-cm (oz-in)	4.9 (6.939)
Weight	W	kg (lbs)	3.2 (7.055)
Diameter	D	mm (In)	215 (8.465)
Length	LG	mm (In)	32.6 (1.283)
Permitted Radial Load		Kg (lbs)	6 (13.23)
Permitted Axial Load		Kg (lbs)	6 (13.23)
Figure of Merit			
Mechanical Time Constant	Tm	ms	11.2
Electrical Time Constant	Te	ms	<0.05
Thermal Specifications			
Thermal Resistance at Rated Speed	RAAR	°C/Watt	1.25
Thermal Resistance at Stall	RAAS	°C/Watt	1.7