

# 3-BALL ROTARY SOLENOID





### Selection Process for 3-Ball Rotary Solenoid

1. Metric (M prefix) and SAE (F prefix) screw thread options are available.
2. The solenoid size is determined from consideration of required torque and effective duty cycle from graphs for the required angle of rotation. This may also be influenced by available power, for a given angle, a larger solenoid will develop the required torque with less electrical power than a smaller device.
3. The coil requirements are determined from tables of coil gauge / duty cycle (ED) for the chosen size of device. Coil rating is specified as AWG size of the coil wire.

4. The mechanical configuration options are chosen to suit the mounting and mechanical attachment of load to the solenoid in the application. These are illustrated later in this selection guide, along with a table which shows how the mechanical options, angle, and direction of rotation are translated into a 3-digit sequence in the solenoid part number. Direction of rotation is defined looking towards the armature plate as shown in attached drawing.

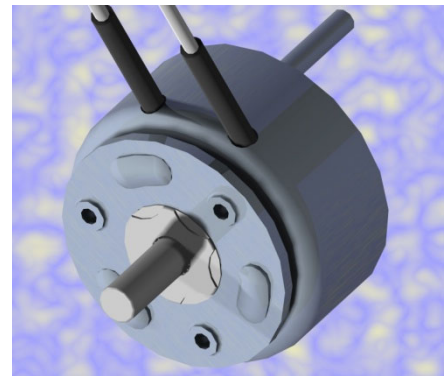

5. The life expectancy of the solenoid is specified by the suffix, R is standard life (2M cycles), RE is extended (10M cycles), RL is long life (50M cycles). Life will be reduced by excessive side loading, particulate contamination, corrosive or otherwise aggressive environments. Life expectancy should be verified under real operating conditions in the customer application to ensure this is sufficient for purpose.

Part Number for 3-Ball Rotary Solenoids				
Example : M491-28-282RE				
Thread	Size	Coil AWG	Options	Life
M - Metric thread F - SAE thread	491	28	283	R - Standard Life RE - Extended Life RL - Long Life

# Size Determination

Device size is determined for the required torque and duty cycle from the tables below, torque is shown on the vertical axis vs ED on the horizontal

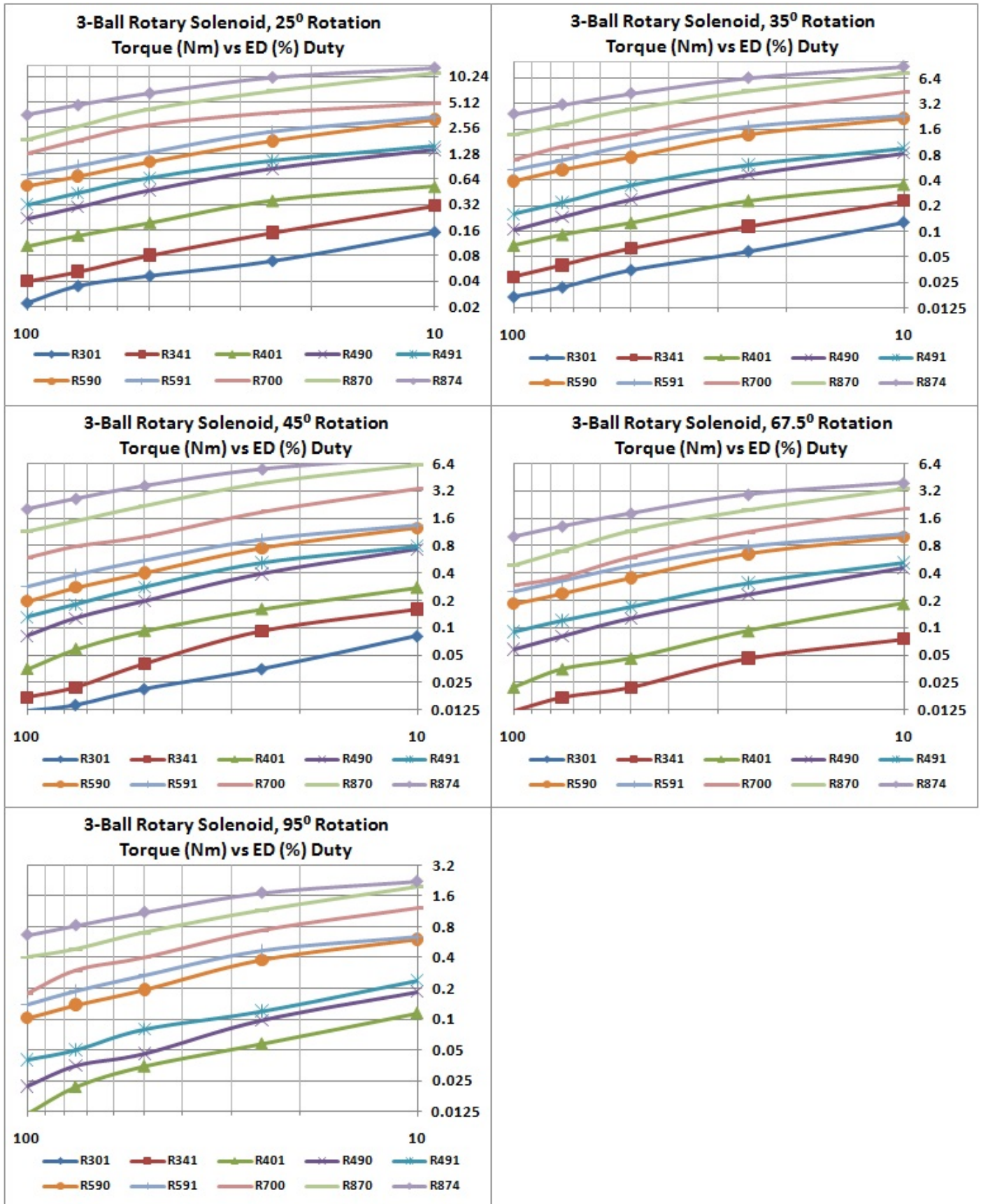

## Specifying Coil AWG

Duty Cycle (%ED)			100%	50%	25%	10%
Maximum 'ON' time			∞	100	36	7
Watts at 20° C			7	14	28	70
ampere-turns at 20° C			425	602	849	1350
AWG no	Resistance	no. turns	Nominal Voltage			
26	1.96	231	3.5	5	7.1	11
27	3.16	296	4.5	6.3	8.9	14
28	5.1	378	5.6	8	11	18
29	6.94	423	7.1	10	14	22
30	11	530	8.9	13	18	28
31	16.9	649	11	16	22	36
32	28.3	858	14	20	28	45

- The coil AWG is determined from tables of coil data for the given part, in the column corresponding to chosen duty cycle, the voltage closest to user supply is picked, and coil AWG corresponding to this is indicated in the LH column (example shows selection for a part operated from 12v supply at 25% duty cycle)
  - In the example illustrated, the selection of a device having higher nominal voltage than the supply is conservative, for maximum torque and speed the 28AWG coil might be more appropriate (see also point below)
  - Allowance should be made for voltage drops in switching devices, and resistive drops in wiring harness when determining the nominal voltage which will be applied to the solenoid.



# Mechanical Configuration

- The direction of rotation of the solenoid is defined looking at the armature plate.
- The standard accessories are shown in the adjacent drawing.
- The dust-cover option is recommended in any application where the solenoid is exposed to dust which can clog or cause abrasive wear to the inclined raceways. This precludes use of the T option.

When you have selected mechanical options required, the last 3 numbers of solenoid P/N can be determined from the table below.

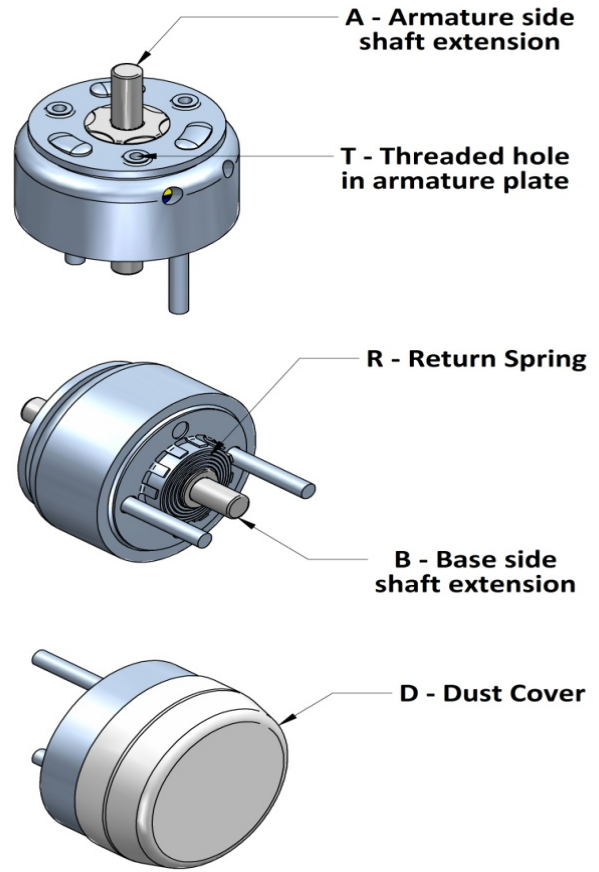

Accessories	25° CW	35° CW*	45° CW	67.5° CW	95° CW	25° CCW	35° CCW	45° CCW	67.5° CCW	95° CCW
A	070	071	072	073	074	075	076	077	078	079
A,T	100	101	102	103	104	105	106	107	108	109
A,T,R	110	111	112	113	114	115	116	117	118	119
A,D	120	121	122	123	124	125	126	127	128	129
A,D,R	130	131	132	133	134	135	136	137	138	139
A,R	140	141	142	143	144	145	146	147	148	149
T	170	171	172	173	174	175	176	177	178	179
T,R	180	181	182	183	184	185	186	187	188	189
B	220	221	222	223	224	225	226	227	228	229
A,B	230	231	232	233	234	235	236	237	238	239
A,B,T	260	261	262	263	264	265	266	267	268	269
A,B,T,R	280	281	282	283	284	285	286	287	288	289
A,B,D	290	291	292	293	294	295	296	297	298	299
A,B,D,R	300	301	302	303	304	305	306	307	308	309
A,B,R	310	311	312	313	314	315	316	317	318	319
B,T	340	341	342	343	344	345	346	347	348	349
B,T,R	360	361	362	363	364	365	366	367	368	369
B,D	370	371	372	373	374	375	376	377	378	379
B,D,R	380	381	382	383	384	385	386	387	388	389
B,R	390	391	392	393	394	395	396	397	398	399

\* 30° rotation in the case of the 191 solenoid

## Thermal Considerations

The coil data for rotary solenoids is based on performance at an ambient temperature of 20°C, with the solenoid mounted on a heatsink as described in individual data sheets. When the solenoid is energised with voltage and duty cycle as specified in the data tables, the coil will reach thermal equilibrium with a coil temperature rise of 85°C above ambient temperature. Standard materials will withstand operation at temperatures of up to 120°C. If ambient temperature or heatsinking conditions are other than indicated, it is advisable that coil temperature is measured under worst case operating conditions by measurement of coil resistance rise in the energised condition.

## Starting Torque

Figures given for starting torque in the solenoid data are gross starting torque with the solenoid energised at 20°C. When a return spring is fitted, the net starting torque will be equal to the gross starting torque minus the spring torque.

## Torque vs Angle Characteristic

The 3-Ball Rotary Solenoid develops rotary torque through mechanical conversion, magnetically the solenoid develops high linear pull-in force along the axis over a short displacement. The rotary torque is produced by 3 helical ball races between the case and armature plate of the solenoid. The inclination of the ball races is not constant, the interaction of this and the magnetic attraction produces a torque which is approximately constant with rotation angle at 25% ED, at 100%ED torque increases as angle increases, at 10%ED torque decreases as rotation angle increases, this is illustrated by the graph below and is typical of all sizes / angles.

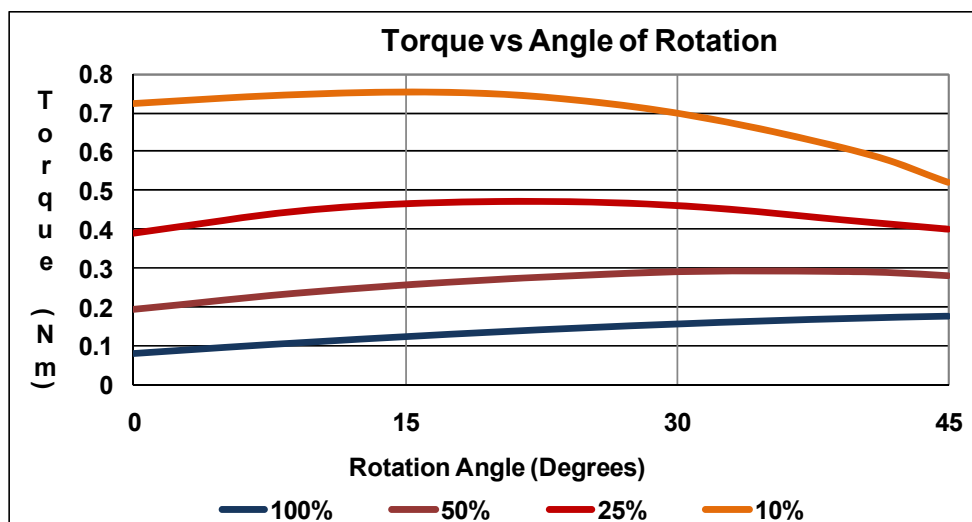

## Axial Displacement

A small axial displacement is associated with the rotation of the 3-Ball Rotary Solenoid. The axial displacement developed in different sizes is given in the table below. This is inherent to the design of the 3-Ball rotary solenoid and must be accommodated in the end application.

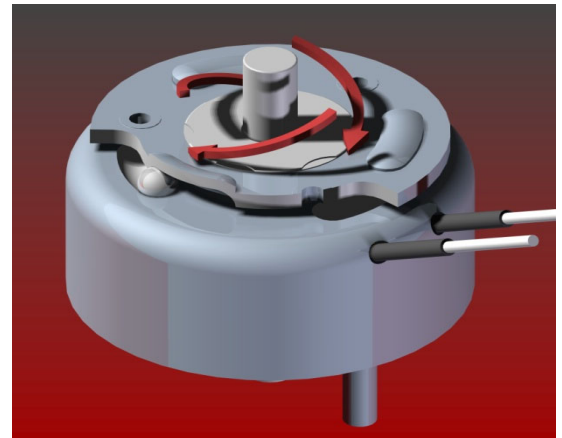

Axial Displacement of 3-Ball Rotary Solenoid								
Solenoid Size	190	301	341	401	490 491	590 591	700	870 874
Axial Displacement (mm)		0.7	0.9	1.2	1.5	1.6	2.3	2.6
Axial Displacement (")	0.00	0.03	0.04	0.05	0.06	0.06	0.09	0.10

## Use of threaded (A) holes in the Armature Plate

Where the threaded holes in the armature plate are used to attach accessories to the solenoid, caution must be taken that screws are not too long, and do not protrude through the armature plate where they can inhibit linear travel and rotation of the solenoid.

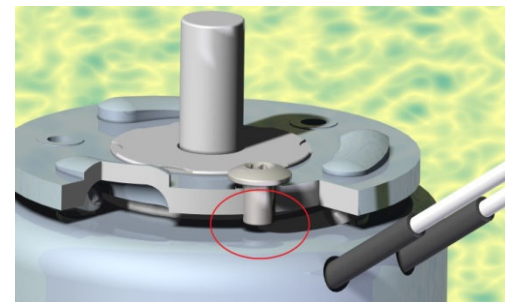

## Restricting the Angle of Rotation

If an application requires an operating angle intermediate to the standard options available, it is possible to limit the rotation angle of the solenoid with an external end-stop, however the following precautions must be observed:

- The external stop should be fitted to limit rotation in the energised direction
- The solenoid must be allowed to return fully to the inbuilt stops in the de-energised position, end stops must not under any circumstances be fitted so as to limit rotation in both directions

Failure to observe these precautions will result in accelerated failure and invalidates any warranty on the life expectancy of the solenoid.

## Customisation of the 3-Ball Rotary Solenoid

- The drawing indicates which components can be easily modified
  - Parts shown in green can be readily modified to customer requirement
  - Parts shown in Blue can be modified subject to selection from a range of available components limited by material size (eg length and thread size of mounting studs is constrained by standard sizes available)
- Modified Shaft – shaft modification is a common requirement, and is possible for qty >100pcs
  - Longer / shorter shaft
  - Flat (D-cut) on shaft
  - Cross-hole through shaft
  - External screw thread
  - Internal screw thread
  - Circlip (E-ring) grooves
  - Splines / knurling for press-fit to load
- Mounting Studs – longer or shorter mounting studs or other thread forms can be supplied subject to availability of suitable materials for qty >100pcs
- Coil Modification – the following are possible subject to confirmation
  - Higher or lower winding resistance
  - Double winding for pick & hold operation
  - High temperature windings up to 180°C
- Return Spring – weaker or stronger return springs are available for qty >100pcs
- Different angle of rotation – this requires significant tooling modification, but may be possible on request for qty >5k-10k pcs
- Leadwires – longer or shorter leadwires can be offered for qty >100pcs
- Modified Armature plate – modification to the armature plate to add crank arms, tabs or other feature is possible for qty >5k-10k pcs
- Drive Pin – addition of drive pins to the armature plate for linkage to the load may be possible for qty >100pcs

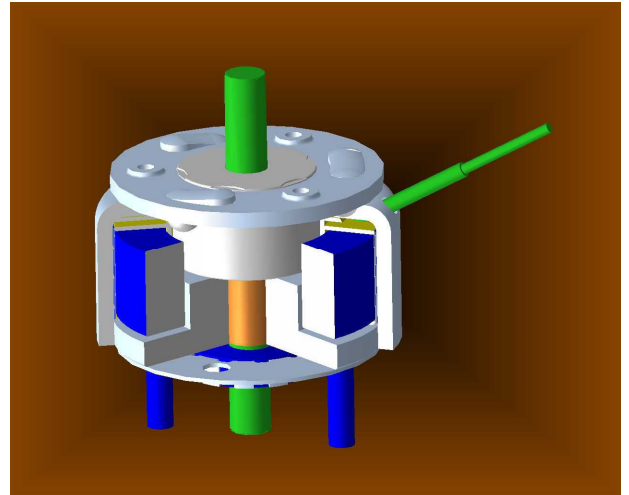



## Specifying Modifications

If requesting mechanical modifications to a rotary solenoid, it will be helpful if changes can be specified based on the drawing below. For normal tolerances on different parameters, please refer to tolerances for the standard part on which design is based.

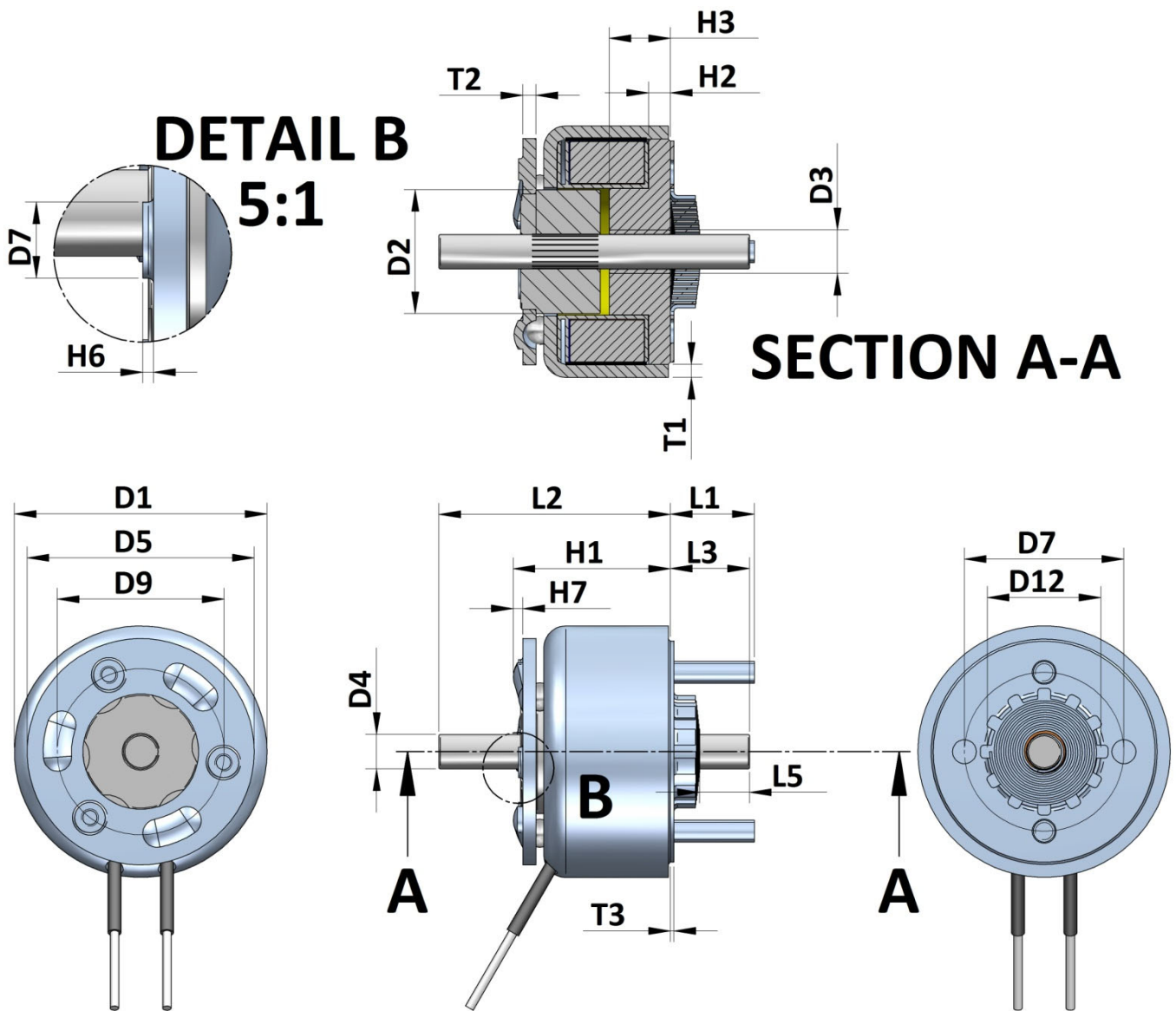



### Size 301

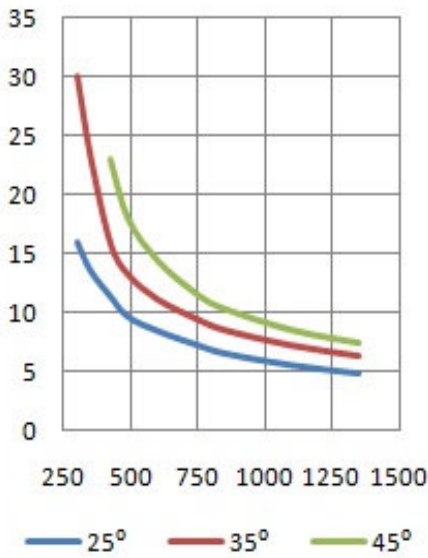

### Size 341

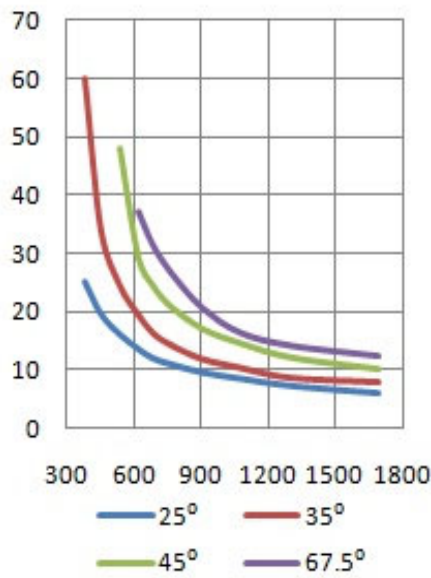

### Size 401

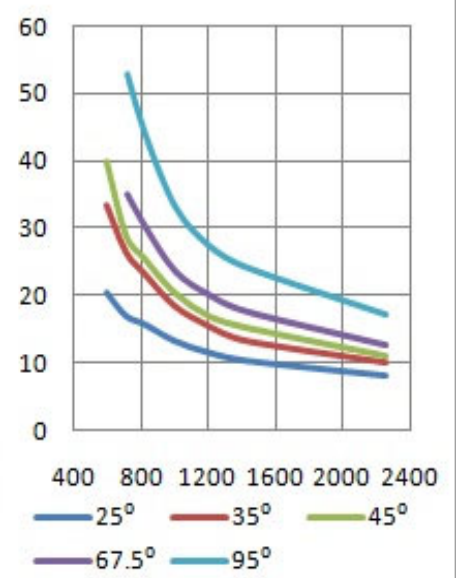

### Size 490

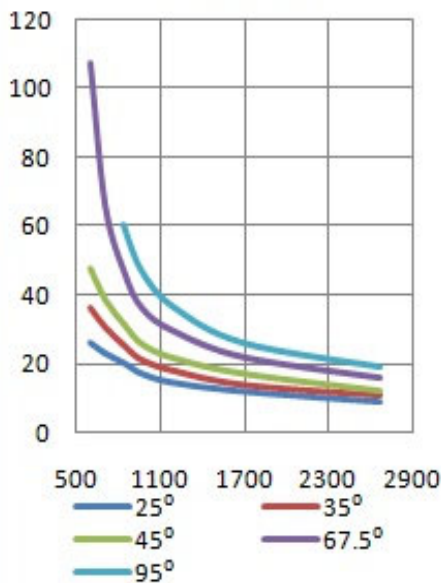

### Size 491

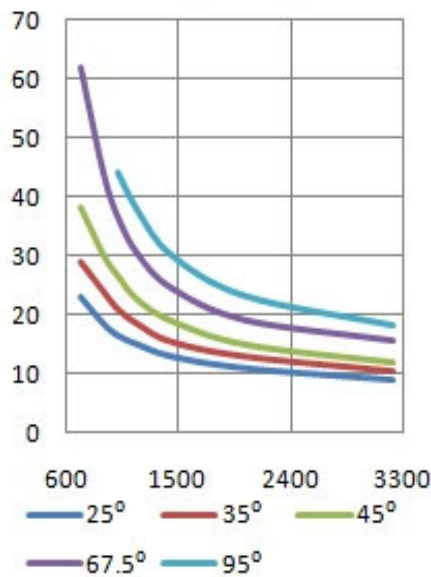

### Size 590

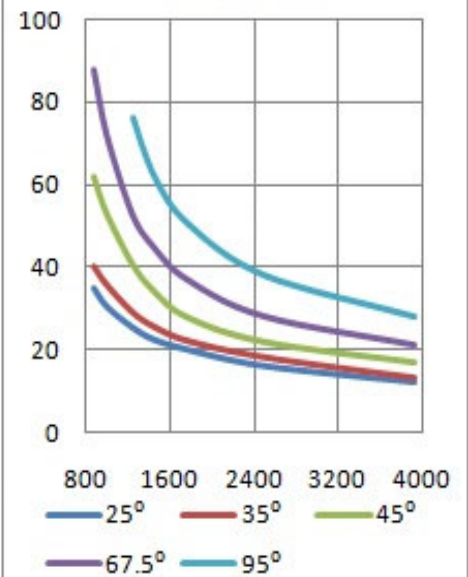

### Size 591

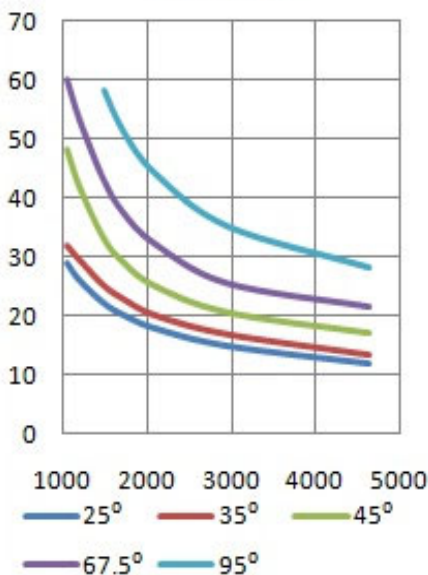

### Size 700

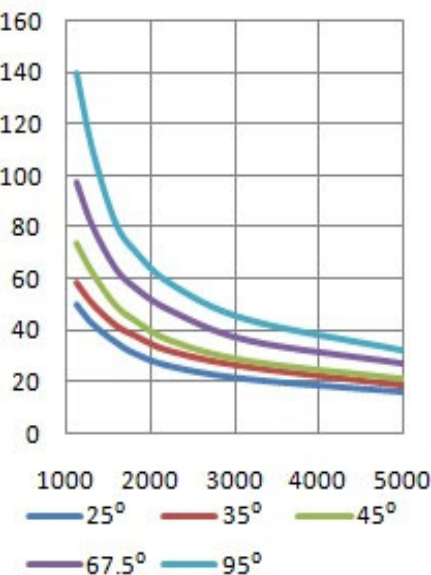

### Size 870

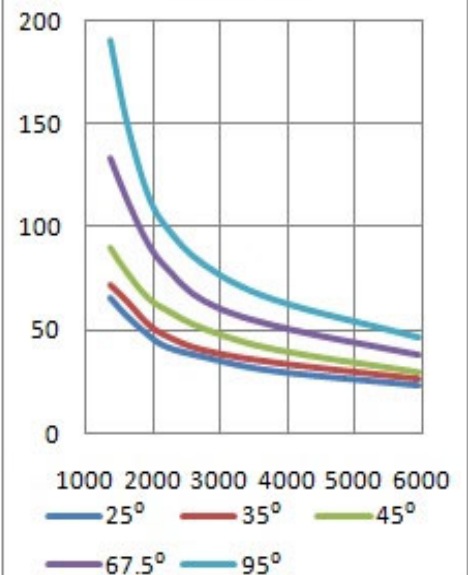



**GEEPLUS**

# Rotary Solenoid size 190

Device drawn in de-energised condition  
 Life Expectancy (cycles): >2M (-R)

Available angle options:  
 30° (CW)  
 Mass 27 grammes

**Note: the M190R rotary solenoid is only manufactured with a 30° rotation angle in mechanical options designated M190-xx-311R, M190-xx-231R & M190-xx-181R, where xx denotes nominal supply voltage at 25% duty cycle.**

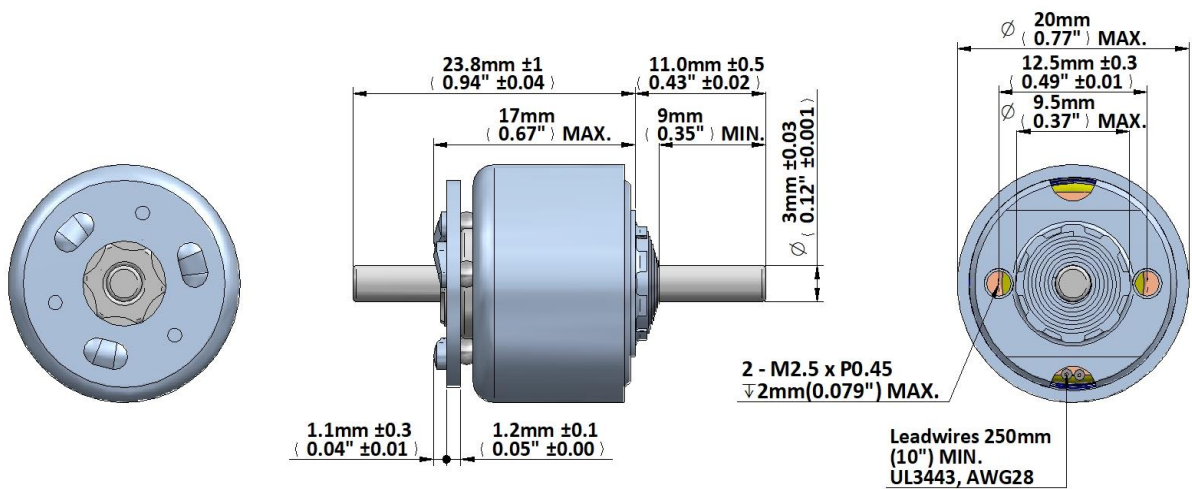

Data at 20°C, device connected to heatsink 60x60x3mm aluminum return spring 2 ~ 4 mNm

duty cycle = $\frac{\text{"on" time}}{\text{"on" time} + \text{"off" time}} \times 100\%$			100% cont.	50% or less	25% or less	10% or less
Max. "on" time in seconds			-	10	3	1
watts at 20°C			-	8	16	40
ampere-turns at 20°			-	382	540	854
Gross starting torque		30°	-	0.01	0.02	0.04
type no.	resistance	number	volts DC			
	Ω±10% (at 20°C)	of turns				
M190-6V-xxxR F190-6V-xxxR	2.3	210	-	4.2	6.0	9.5
M190-12V-xxxR F190-12V-xxxR	9.0	420	-	8.5	12	19
M190-24V-xxxR F190-24V-xxxR	36	800	-	17	24	38
M190-48V-xxxR F190-48V-xxxR	144	1600	-	34	48	76

Insulation Resistance >100MΩ, 500VDC Megger

Dielectric Strength 1000VAC, 50/60Hz, 1 minute

Class E (120°C) insulation class

Geeplus reserves the right to change specifications without notice

[www.geeplus.com](http://www.geeplus.com)



**GEEPLUS**

# Rotary Solenoid size 301

Device drawn in de-energised condition  
 Life Expectancy (cycles): >2M (-R), >10M (-RE), >50M (-RL)

Available angle options:  
 25°, 35°, 45° (CW/CCW)  
 Mass 56 grammes

Available mechanical options:

- A: shaft extension (armature side)
- B: shaft extension (base side)
- D: dust cover over the armature
- R: return spring
- T: tapped holes in armature plate

Note:  
 Screws should **NOT** pass the bottom of the armature plate.

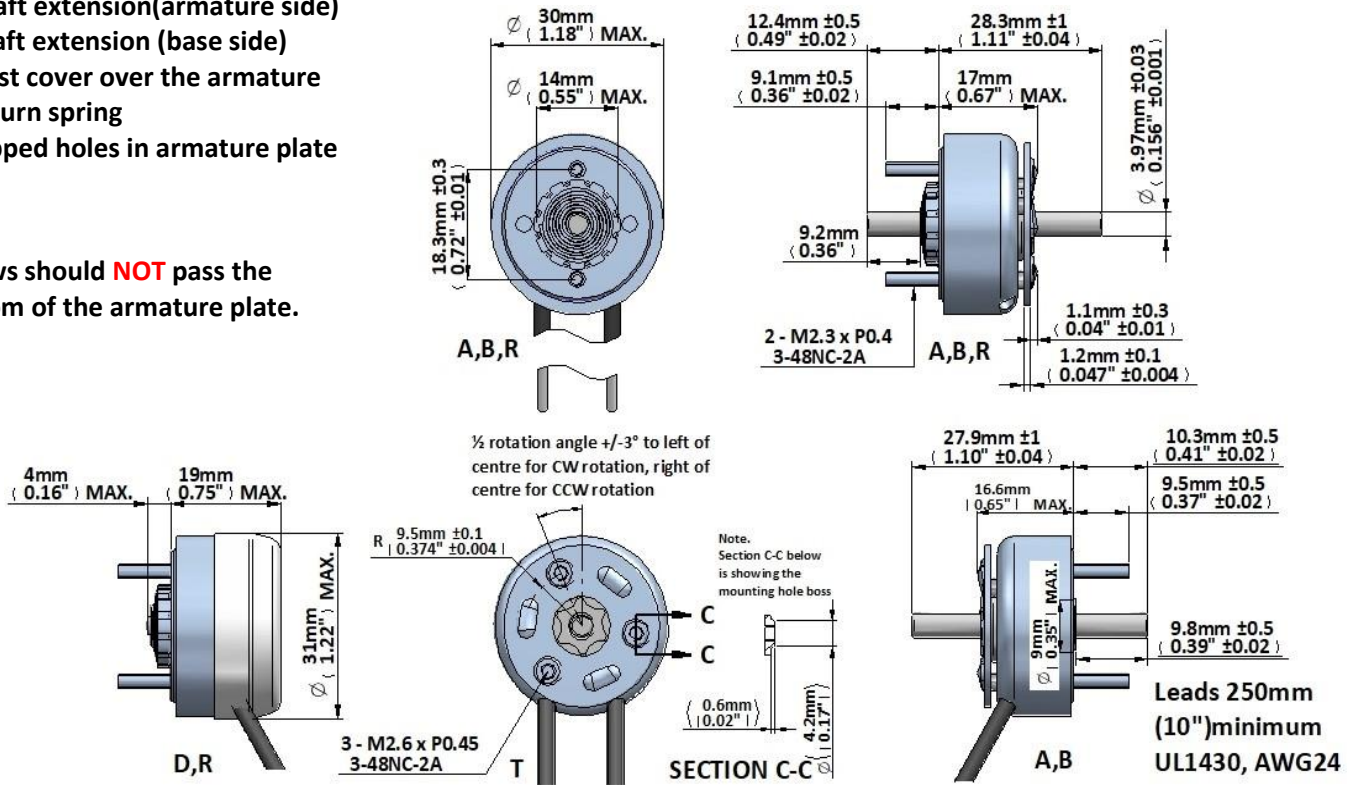

Data at 20°C, device connected to heatsink 90x90x3mm aluminum return spring 5,5 ~ 9 mNm

duty cycle = $\frac{\text{"on" time}}{\text{"on" time} + \text{"off" time}} \times 100\%$		100% cont.	75% or less	50% or less	25% or less	10% or less	
Max. "on" time in seconds		∞	105	100	36	7	
watts at 20°C		7	9.3	14	28	70	
ampere-turns at 20°		425	490	602	849	1350	
Gross starting torque at 20°C (Nm)		25°	0.022	0.035	0.046	0.069	0.150
		35°	0.017	0.022	0.035	0.058	0.127
		45°	0.012	0.014	0.021	0.035	0.081
		67,5°	-	-	-	-	-
		95°	-	-	-	-	-
AWG no.	resistance Ω±10% (at 20°C)	number of turns	volts DC				
26	1.96	231	3.5	4.1	5.0	7.1	11
27	3.16	296	4.5	5.1	6.3	8.9	14
28	5.10	378	5.6	6.5	8.0	11	18
29	6.94	423	7.1	8.1	10	14	22
30	11.0	530	8.9	10	13	18	28
31	16.9	649	11	12	16	22	36
32	28.3	858	14	16	20	28	45
33	42.8	1036	18	20	25	35	56
34	69.6	1312	22	26	32	45	71
35	112	1674	28	32	39	56	89
36	148	1765	35	41	50	71	112
37	221	2090	35	51	63	89	142
38	352	2650	56	65	80	112	178
39	568	3380	71	81	100	141	224
40	882	4200	89	102	126	178	283

Insulation Resistance >100MΩ, 500VDC Megger

Dielectric Strength 1000VAC, 50/60Hz, 1 minute

Class E (120°C) insulation class

Geepus reserves the right to change specifications without notice

[www.geepus.com](http://www.geepus.com)





**GEEPLUS**

# Rotary Solenoid size 341

Device drawn in de-energised condition  
 Life Expectancy (cycles): >2M (-R), >10M (-RE), >50M (-RL)

Available angle options:  
 25°, 35°, 45°, 67,5° (CW/CCW)  
 Mass 97 grammes

- Available mechanical options:  
 A: shaft extension (armature side)  
 B: shaft extension (base side)  
 D: dust cover over the armature  
 R: return spring  
 T: tapped holes in armature plate

Note.  
 Screws should **NOT** pass the bottom of the armature plate.

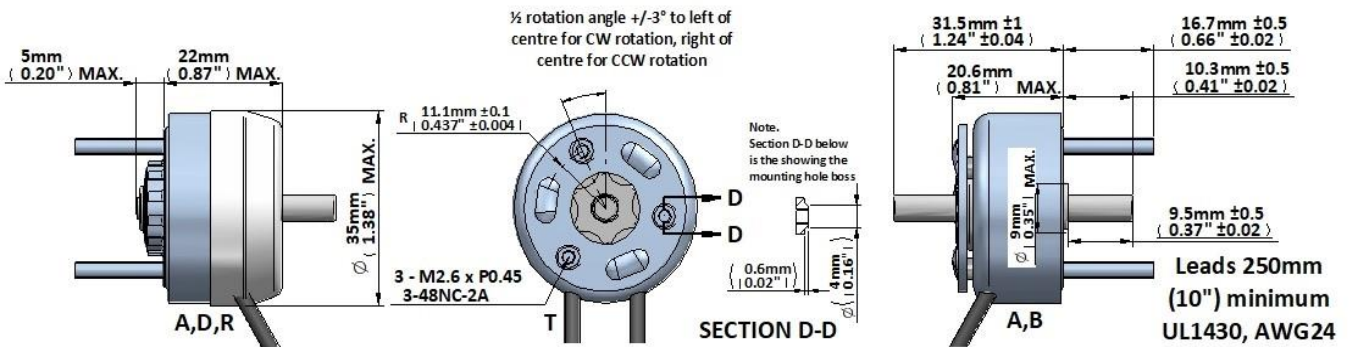
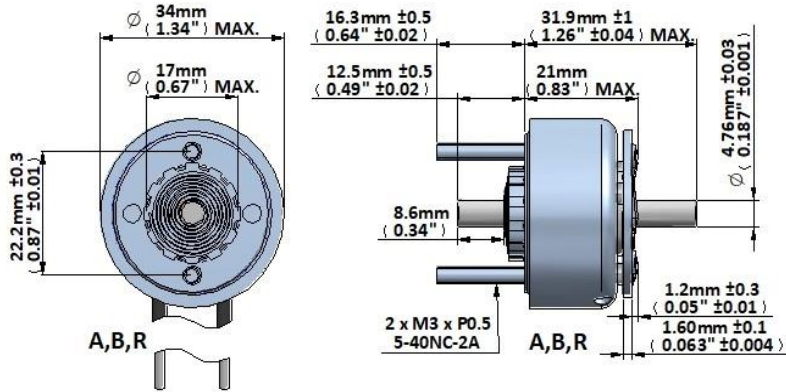

Data at 20°C, device connected to heatsink 120x120x3mm aluminum return spring 11 ~ 17 mNm

duty cycle = $\frac{\text{"on" time}}{\text{"on" time} + \text{"off" time}} \times 100\%$		100% cont.	75% or less	50% or less	25% or less	10% or less	
Max. "on" time in seconds		∞	107	100	36	8	
watts at 20°C		9	12	18	36	90	
ampere-turns at 20°		535	618	756	1070	1690	
Gross starting torque at 20°C (Nm)		25°	0.040	0.052	0.081	0.150	0.310
		35°	0.029	0.040	0.063	0.115	0.230
		45°	0.017	0.022	0.040	0.092	0.16
		67,5°	0.012	0.017	0.022	0.046	0.075
AWG no.	resistance $\Omega \pm 10\%$ (at 20°C)	number of turns	volts DC				
	25		1.97	252	4.2	4.8	5.9
26	3.26	328	5.3	6.1	7.5	11.0	17.0
27	5.04	405	6.7	7.7	9.4	13.0	21.0
28	8.02	510	8.4	9.7	12.0	17	26
29	12.21	627	10	12	15	21	33
30	19.2	780	13	15	19	26	42
31	31.8	1008	17	19	24	33	53
32	47.0	1215	21	24	30	42	66
33	75.3	1530	26	31	37	53	84
34	120.5	1900	33	38	40	67	105
35	198	2486	42	48	59	84	133
36	280	2700	53	61	75	106	167
37	426	3350	67	77	94	133	210
38	648	4050	84	97	118	168	264
39	1020	5050	105	122	149	211	333
40	1667	6590	133	153	187	265	419

Insulation Resistance >100MΩ, 500VDC Megger

Dielectric Strength 1000VAC, 50/60Hz, 1 minute

Class E (120°C) insulation class

Geeplus reserves the right to change specifications without notice

[www.geeplus.com](http://www.geeplus.com)





GEEPLUS

# Rotary Solenoid size 401

Device drawn in de-energised condition

Life Expectancy (cycles): >2M (-R),

>10M (-RE), >50M (-RL)

Available mechanical options:

A: shaft extension(armature side)

B: shaft extension (base side)

D: dust cover over the armature

R: return spring

T: tapped holes in armature plate

Note.

Screws should **NOT** pass the bottom of the armature plate.

Available angle options:

25°, 35°, 45°, 67,5°, 95° (CW/CCW)

Mass 200 grammes

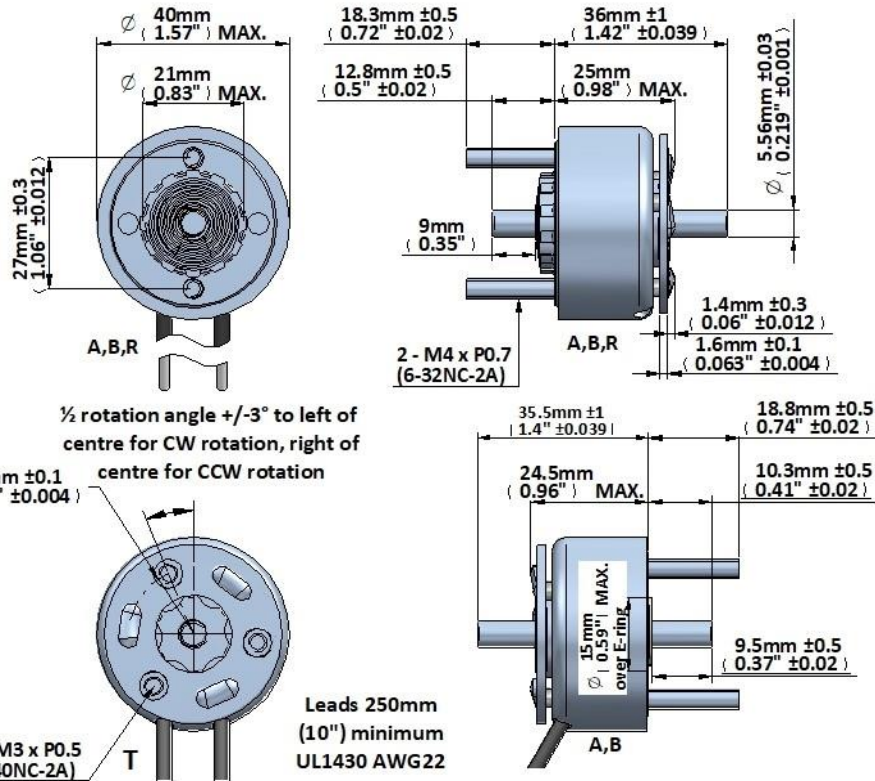

Data at 20°C, device connected to heatsink 160x160x3mm aluminum

return spring 16,5 ~ 24 mNm

duty cycle = $\frac{\text{"on" time}}{\text{"on" time} + \text{"off" time}} \times 100\%$		100% cont.	75% or less	50% or less	25% or less	10% or less	
Max. "on" time in seconds		∞	108	100	36	9	
watts at 20°C		12.5	16.5	25	50	125	
ampere-turns at 20°		714	825	1000	1425	2250	
Gross starting torque at 20°C (Nm)		25°	0.104	0.138	0.195	0.355	0.520
		35°	0.069	0.092	0.127	0.230	0.355
		45°	0.035	0.058	0.092	0.160	0.276
		67,5°	0.022	0.035	0.046	0.092	0.185
		95°	0.012	0.022	0.035	0.058	0.115
AWG no.	resistance Ω±10% (at 20°C)	number of turns	volts DC				
	25		3.50	384	6.6	7.8	9.5
26	5.67	486	8.4	9.7	12	17	27
27	8.76	600	11	13	16	22	35
28	13.8	748	13	15	18	26	42
29	22.6	975	17	19	23	33	52
30	34.8	1190	21	25	30	42	67
31	56.7	1520	27	31	38	54	85
32	88.3	1908	35	41	49	70	110
33	138	2360	43	50	60	86	138
34	216	2904	53	61	75	106	168
35	351	3725	67	78	95	132	213
36	480	4000	85	98	119	169	268
37	720	9450	105	121	147	210	332
38	1150	6200	132	153	185	264	-
39	1920	8350	166	191	232	332	-
40	3000	10000	210	250	300	-	-

Insulation Resistance >100MΩ, 500VDC Megger

Dielectric Strength 1000VAC, 50/60Hz, 1 minute

Class E (120°C) insulation class

Geeplus reserves the right to change specifications without notice

[www.geeplus.com](http://www.geeplus.com)



**GEEPLUS**

# Rotary Solenoid size 490

Device drawn in de-energised condition  
 Life Expectancy (cycles):  
 >2M (-R), >10M (-RE), >50M (-RL)

Available angle options:  
 25°, 35°, 45°, 67,5°, 95° (CW/CCW)  
 Mass 250 grammes

Available mechanical options:  
 A: shaft extension (armature side)  
 B: shaft extension (base side)  
 D: dust cover over the armature  
 R: return spring  
 T: tapped holes in armature plate

Note.  
 Screws should **NOT** pass the bottom of the armature plate.

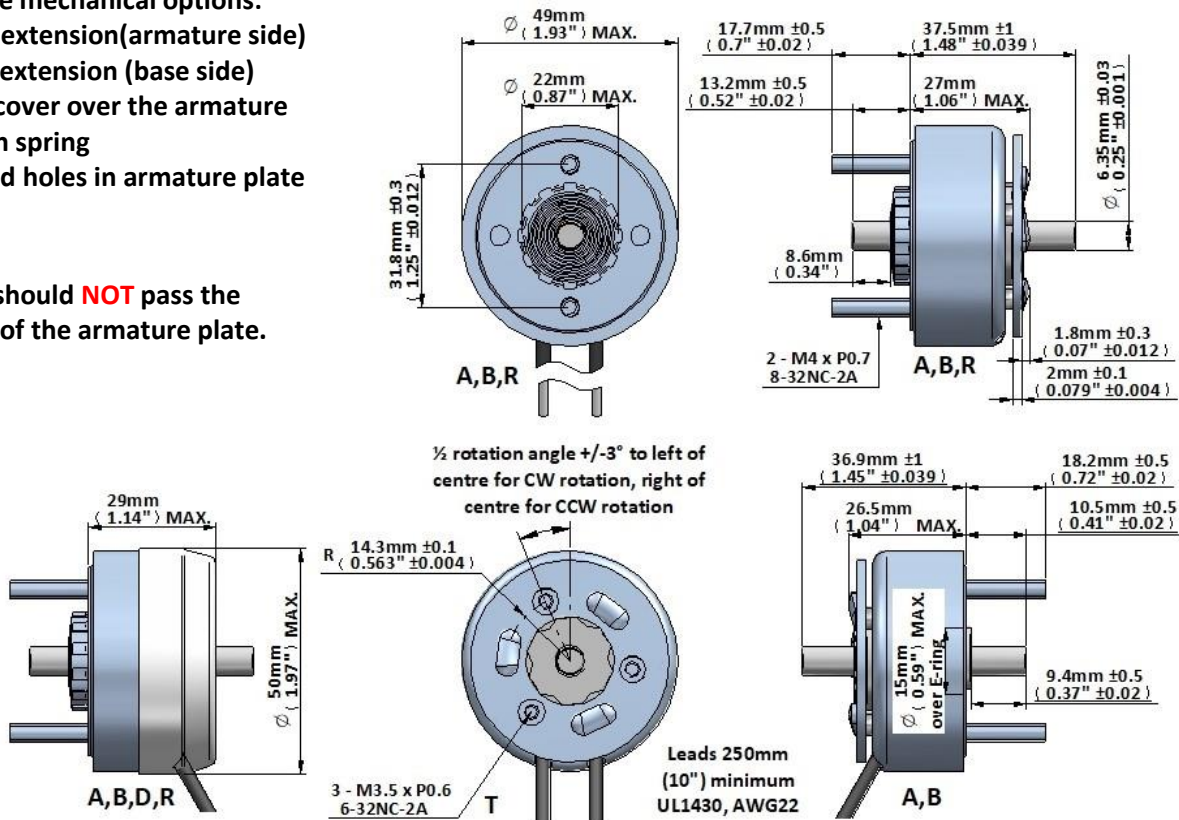

Data at 20°C, device connected to heatsink 190x190x3mm aluminum return spring 26 ~ 35 mNm

duty cycle = $\frac{\text{"on" time}}{\text{"on" time} + \text{"off" time}} \times 100\%$		100% cont.	75% or less	50% or less	25% or less	10% or less	
Max. "on" time in seconds		∞	110	100	36	10	
watts at 20°C		21	28	42	84	210	
ampere-turns at 20°		842	966	1190	1685	2660	
Gross starting torque at 20°C (Nm)		25°	0.220	0.3	0.47	0.84	1.39
		35°	0.104	0.15	0.24	0.47	0.84
		45°	0.081	0.127	0.195	0.390	0.725
		67,5°	0.058	0.081	0.127	0.230	0.450
		95°	0.022	0.035	0.046	0.098	0.185
AWG no.	resistance	number of turns	volts DC				
	$\Omega \pm 10\%$ (at 20°C)						
24	3.20	360	7.6	8.7	11	15	24
25	4.91	440	9.5	11	13	19	30
26	7.72	550	12	14	17	24	38
27	11.1	636	15	17	21	30	48
28	18.8	840	19	22	27	38	60
29	30.5	1088	24	28	34	48	76
30	44.9	1275	30	34	43	60	95
31	70.9	1596	38	43	54	76	120
32	109	1974	48	56	67	95	150
33	175	2496	60	69	85	120	190
34	270	3042	76	87	107	151	239
35	414	3600	95	109	134	190	301
36	610	4200	122	140	173	245	386
37	940	5200	151	174	213	301	-
38	1560	6820	190	219	268	379	-

Insulation Resistance >100MΩ, 500VDC Megger

Dielectric Strength 1000VAC, 50/60Hz, 1 minute

Class E (120°C) insulation class

Geepus reserves the right to change specifications without notice

[www.geepus.com](http://www.geepus.com)



**GEEPLUS**

# Rotary Solenoid size 491

Device drawn in de-energised condition  
 Life Expectancy (cycles): >2M (-R), >10M (-RE), >50M (-RL)

Available mechanical options:

- A: shaft extension (armature side)
- B: shaft extension (base side)
- D: dust cover over the armature
- R: return spring
- T: tapped holes in armature plate

Note:  
 Screws should **NOT** pass the bottom of the armature plate.

Available angle options:  
 25°, 35°, 45°, 67,5°, 95° (CW/CCW)  
 Mass 330 grammes

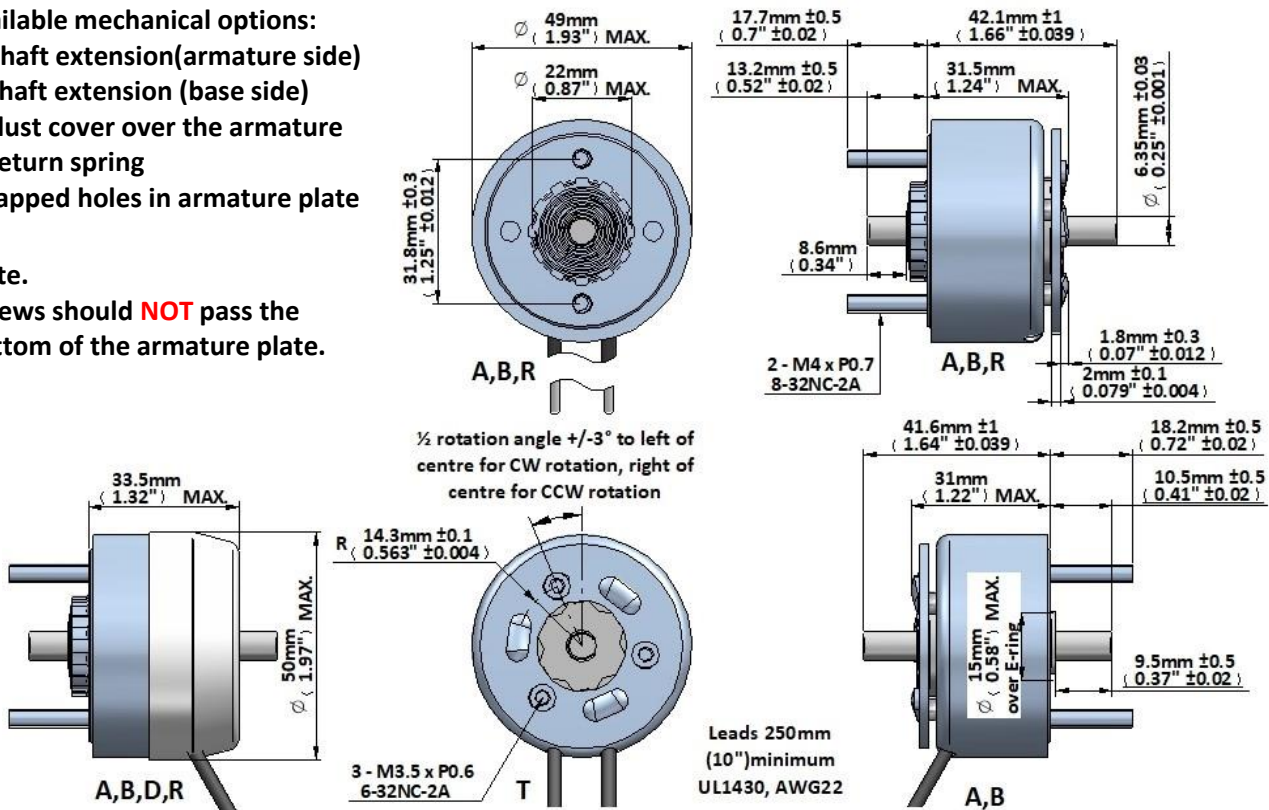

Data at 20°C, device connected to heatsink 190x190x3mm aluminum return spring 26 ~ 35 mNm

duty cycle = $\frac{\text{"on" time}}{\text{"on" time} + \text{"off" time}} \times 100\%$		100% cont.	75% or less	50% or less	25% or less	10% or less	
Max. "on" time in seconds		∞	110	100	36	10	
watts at 20°C		21	28	42	84	210	
ampere-turns at 20°		1015	1172	1440	2030	3210	
Gross starting torque at 20°C (Nm)		25°	0.32	0.44	0.66	1.04	1.54
		35°	0.16	0.22	0.35	0.61	0.96
		45°	0.13	0.18	0.28	0.52	0.79
		67,5°	0.09	0.12	0.17	0.31	0.52
		95°	0.04	0.05	0.08	0.12	0.24
AWG no.	resistance $\Omega \pm 10\%$ (at 20°C)	number of turns	volts DC				
21	1.00	228	4.5	5.2	6.4	8.9	14.1
22	1.68	301	5.7	6.6	8.1	11.4	17.9
23	2.70	384	7.2	8.3	10.1	14.3	23
24	4.30	486	9.0	10.4	12.7	18	28
25	6.66	590	11.5	13.2	16.2	23	36
26	10.3	737	14.0	16.1	20	28	44
27	15.7	900	17.7	20.4	25	35	56
28	26.6	1190	23	27	32	45	72
29	38.0	1380	28	32	40	56	89
30	62.1	1768	36	41	51	71	113
31	96.1	2166	45	52	64	90	143
32	157	2816	57	66	80	113	179
33	241	3432	71	82	101	143	226
34	364	4108	90	104	128	180	285
35	566	4920	117	136	166	234	370
36	910	6340	146	168	207	292	462
37	1224	6800	183	211	260	366	-

Insulation Resistance >100MΩ, 500VDC Megger

Dielectric Strength 1000VAC, 50/60Hz, 1 minute

Class E (120°C) insulation class

Geepus reserves the right to change specifications without notice

[www.geepus.com](http://www.geepus.com)



**GEEPLUS**

# Rotary Solenoid size 590

Device drawn in de-energised condition  
 Life Expectancy (cycles): >2M (-R),  
 >10M (-RE), >50M (-RL)

Available angle options:  
 25°, 35°, 45°, 67,5°, 95° (CW/CCW)  
 Mass 506 grammes

Available mechanical options:

- A: shaft extension(armature side)
- B: shaft extension (base side)
- D: dust cover over the armature
- R: return spring
- T: tapped holes in armature plate

**Note.**

Screws should **NOT** pass the bottom of the armature plate.

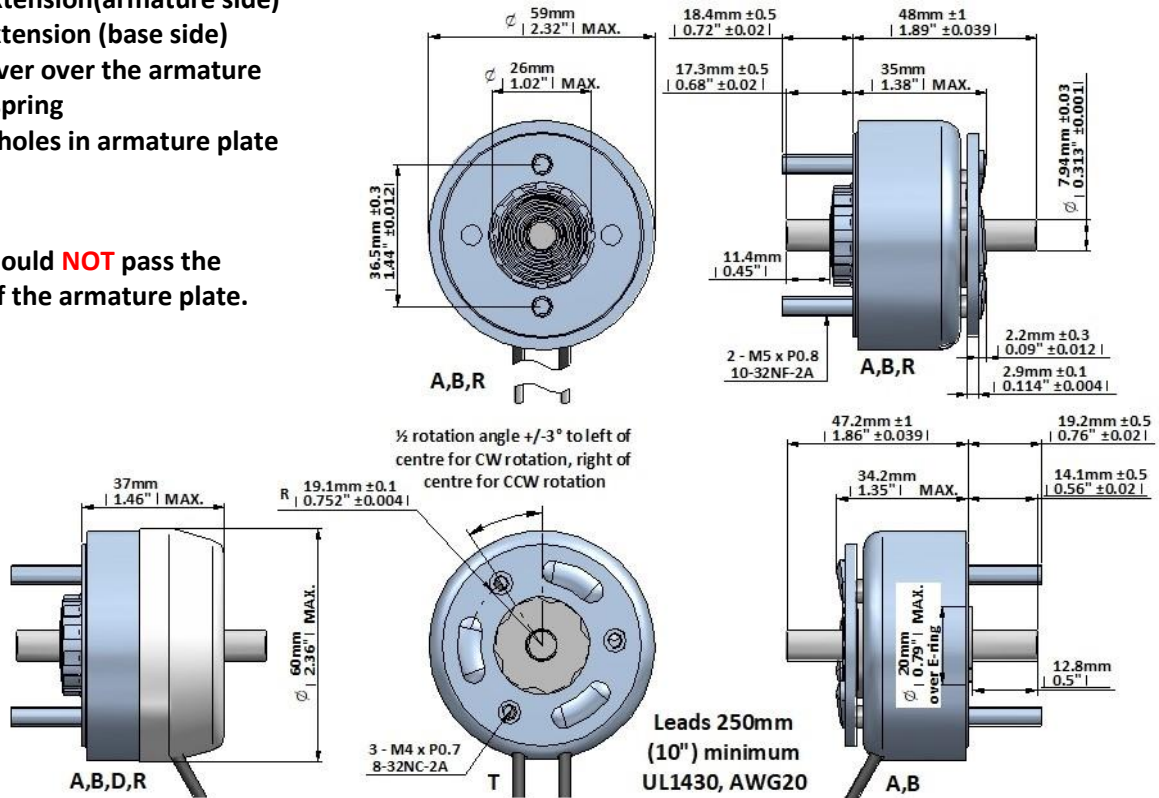

Data at 20°C, device connected to heatsink 310x310x3mm aluminum return spring 45 ~ 65 mNm

duty cycle = $\frac{\text{"on" time}}{\text{"on" time} + \text{"off" time}} \times 100\%$		100% cont.	75% or less	50% or less	25% or less	10% or less	
Max. "on" time in seconds		∞	115	87	36	13	
watts at 20°C		29	38.5	58	116	290	
ampere-turns at 20°		1240	1440	1760	2490	3920	
Gross starting torque at 20°C (Nm)		25°	0.53	0.69	1.02	1.8	3.2
		35°	0.39	0.53	0.75	1.38	2.14
		45°	0.195	0.276	0.40	0.75	1.26
		67,5°	0.184	0.240	0.355	0.65	1.00
		95°	0.103	0.138	0.195	0.38	0.60
AWG no.	resistance	number of turns	volts DC				
	$\Omega \pm 10\%$ (at 20°C)						
22	2.23	336	8.3	9.6	12	16	26
23	3.60	432	10	12	15	21	33
24	5.24	500	13	15	18	26	41
25	9.51	708	16	19	23	33	52
26	14.4	858	21	24	29	41	66
27	23.7	1110	26	30	37	52	83
28	38.2	1411	33	38	47	66	104
29	54.7	1638	41	48	59	83	131
30	93.7	2184	52	61	74	104	165
31	143	2645	66	76	93	131	207
32	223	3328	83	96	117	165	261
33	338	4004	104	121	147	208	329
34	550	5088	131	152	185	262	-
35	790	5860	165	192	233	330	-
36	1233	7260	208	242	294	-	-

Insulation Resistance >100MΩ, 500VDC Megger

Dielectric Strength 1000VAC, 50/60Hz, 1 minute

Class E (120°C) insulation class

Geepus reserves the right to change specifications without notice

[www.geepus.com](http://www.geepus.com)





**GEEPLUS**

# Rotary Solenoid size 591

Device drawn in de-energised condition  
 Life Expectancy (cycles): >2M (-R),  
 >10M (-RE), >50M (-RL)

Available mechanical options:

- A: shaft extension (armature side)
- B: shaft extension (base side)
- D: dust cover over the armature
- R: return spring
- T: tapped holes in armature plate

Available angle options:  
 25°, 35°, 45°, 67,5°, 95° (CW/CCW)  
 Mass 615 grammes

Note.  
 Screws should **NOT** pass the  
 bottom of the armature plate.

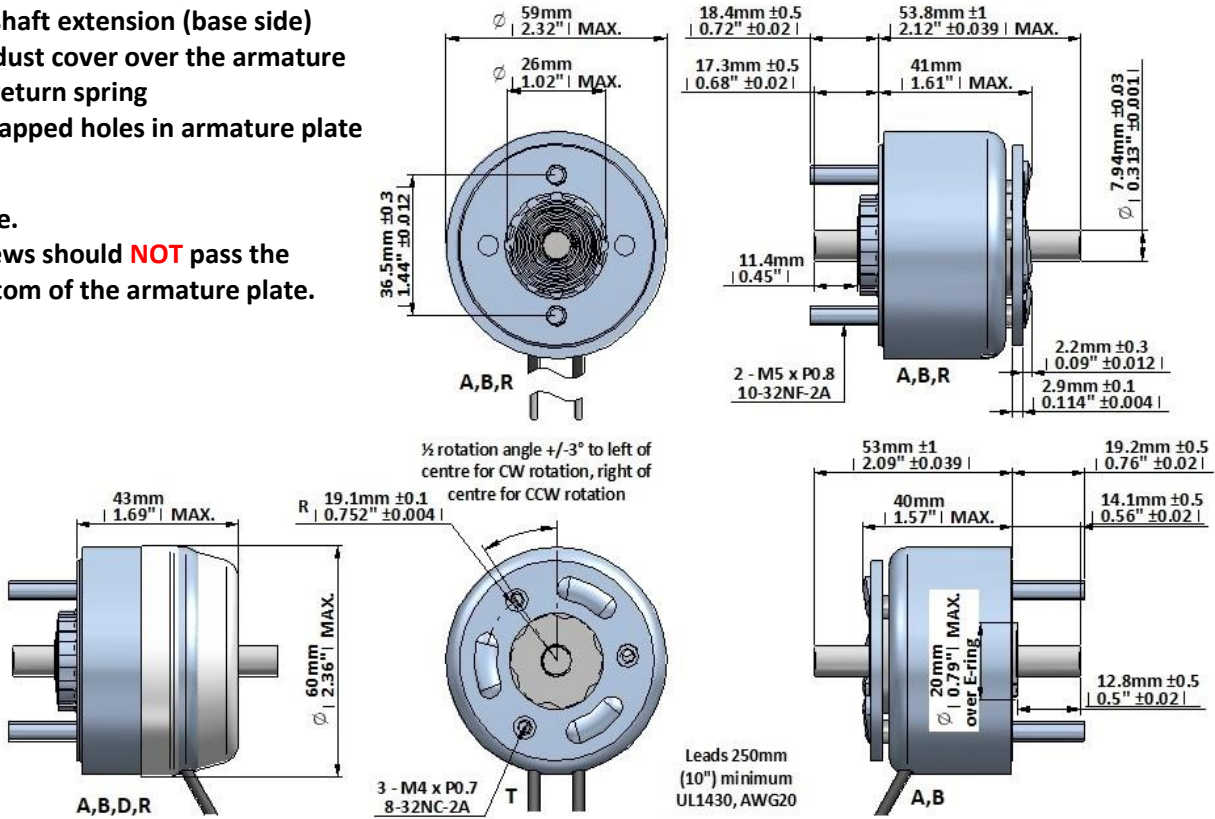

Data at 20°C, device connected to heatsink 310x310x3mm aluminum return spring 45 ~ 65 mNm

duty cycle = $\frac{\text{"on" time}}{\text{"on" time} + \text{"off" time}} \times 100\%$		100% cont.	75% or less	50% or less	25% or less	10% or less	
Max. "on" time in seconds		∞	95	87	36	13	
watts at 20°C		32	43	64	128	320	
ampere-turns at 20°		1480	1710	2080	2940	4620	
Gross starting torque at 20°C (Nm)		25°	0.72	0.92	1.33	2.33	3.45
		35°	0.53	0.69	1.03	1.70	2.27
		45°	0.28	0.38	0.55	0.94	1.36
		67,5°	0.25	0.33	0.48	0.78	1.07
		95°	0.14	0.19	0.27	0.47	0.64
AWG no.	resistance	number of turns	volts DC				
	$\Omega \pm 10\%$ (at 20°C)						
20	1.23	295	6.2	7.1	8.7	12.3	19.3
21	1.75	340	7.6	8.8	10.7	15.1	24
22	2.79	446	9.3	10.7	13.0	18.4	29
23	4.54	567	11.9	13.7	16.7	24	37
24	6.93	690	14.9	17.2	21	30	46
25	12.5	910	20	24	29	40	63
26	18.4	1120	24	28	34	48	76
27	33.4	1500	33	38	46	65	103
28	36.4	1750	39	45	55	78	122
29	74.5	2232	49	57	69	98	154
30	125.5	2940	63	73	89	126	197
31	199	3611	82	94	115	162	255
32	302	4350	103	119	144	204	321
33	417	5010	123	142	173	245	385

Insulation Resistance >100MΩ, 500VDC Megger

Dielectric Strength 1000VAC, 50/60Hz, 1 minute

Class E (120°C) insulation class

Geeplus reserves the right to change specifications without notice

[www.geeplus.com](http://www.geeplus.com)





**GEEPLUS**

# Rotary Solenoid size 700

Device drawn in de-energised condition  
 Life Expectancy (cycles): >2M (-R),  
 >10M (-RE), >50M (-RL)

Available angle options:  
 25°, 35°, 45°, 67,5°, 95° (CW/CCW)  
 Mass 1013 grammes

Available mechanical options:

- A: shaft extension (armature side)
- B: shaft extension (base side)
- D: dust cover over the armature
- R: return spring
- T: tapped holes in armature plate

Note.  
 Screws should **NOT** pass the bottom of the armature plate.

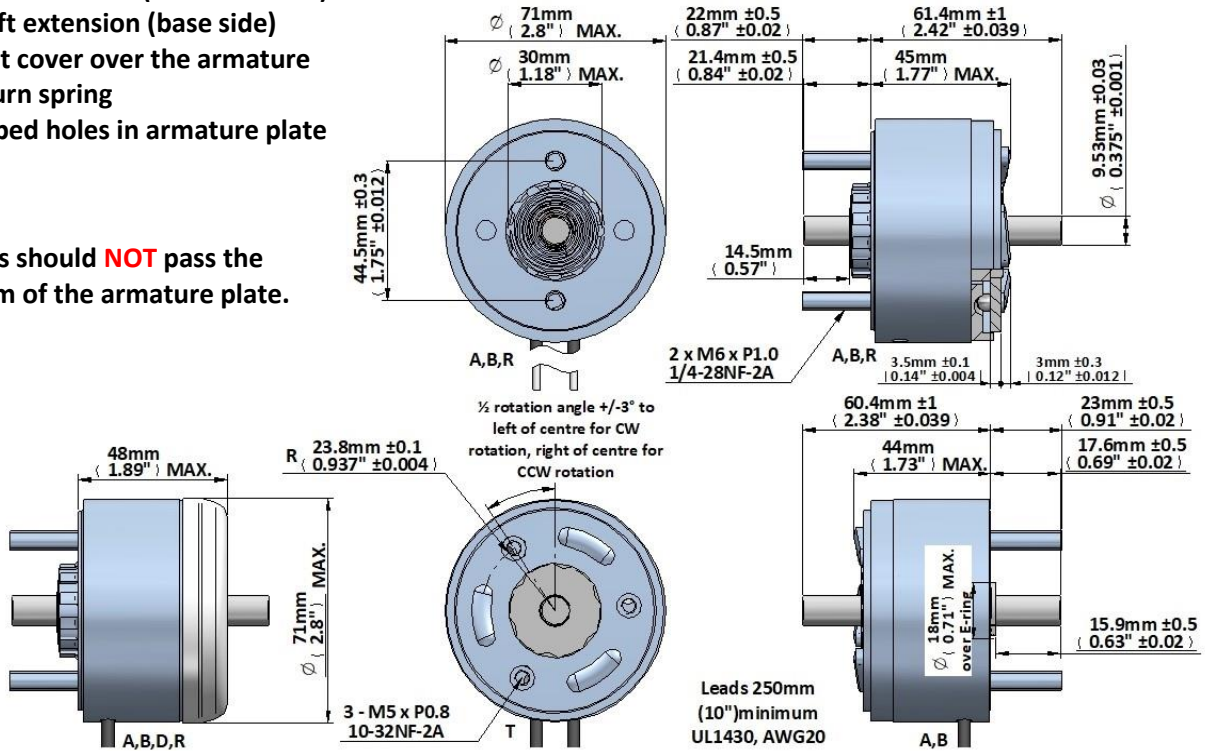

Data at 20°C, device connected to heatsink 390x390x3mm aluminum return spring 75 ~ 105 mNm

duty cycle = $\frac{\text{"on" time}}{\text{"on" time} + \text{"off" time}} \times 100\%$		100% cont.	75% or less	50% or less	25% or less	10% or less	
Max. "on" time in seconds		∞	112	80	37	16	
watts at 20°C		35	46.5	70	140	350	
ampere-turns at 20°		1570	1800	2230	3150	5000	
Gross starting torque at 20°C (Nm)		25°	1.27	2.12	2.74	3.8	4.9
		35°	0.69	0.99	1.38	2.53	4.37
		45°	0.58	0.78	1.0	1.88	3.42
		67,5°	0.288	0.355	0.59	1.12	2.01
95°	0.178	0.3	0.4	0.735	1.21		
AWG no.	resistance $\Omega \pm 10\%$ (at 20°C)	number of turns	volts DC				
	20		1.88	368	8	9.3	11
21	3.01	468	10	11	14	20	32
22	4.82	580	13	15	18	26	41
23	8.1	780	16	19	23	33	52
24	12.3	949	20	23	29	41	65
25	19	1148	26	30	37	52	83
26	30.8	1472	33	38	46	66	105
27	48.8	1854	41	47	59	83	132
28	81.1	2436	52	60	75	105	166
29	121	2944	64	74	92	130	206
30	190	3650	82	94	118	166	264
31	275	4175	104	119	147	209	331
32	440	5792	119	137	170	240	-
33	735	7000	165	191	235	331	-
34	995	7600	204	239	288	-	-

Insulation Resistance >100MΩ, 500VDC Megger

Dielectric Strength 1000VAC, 50/60Hz, 1 minute

Class E (120°C) insulation class

Geeplus reserves the right to change specifications without notice

[www.geeplus.com](http://www.geeplus.com)



**GEEPLUS**

# Rotary Solenoid size 870

Device drawn in de-energised condition  
 Life Expectancy (cycles): >2M (-R),  
 >10M (-RE), >50M (-RL)

Available angle options:  
 25°, 35°, 45°, 67,5°, 95° (CW/CCW)  
 Mass 1885 grammes

Available mechanical options:

- A: shaft extension (armature side)
- B: shaft extension (base side)
- D: dust cover over the armature
- R: return spring
- T: tapped holes in armature plate

Note.  
 Screws should **NOT** pass the bottom of the armature plate.

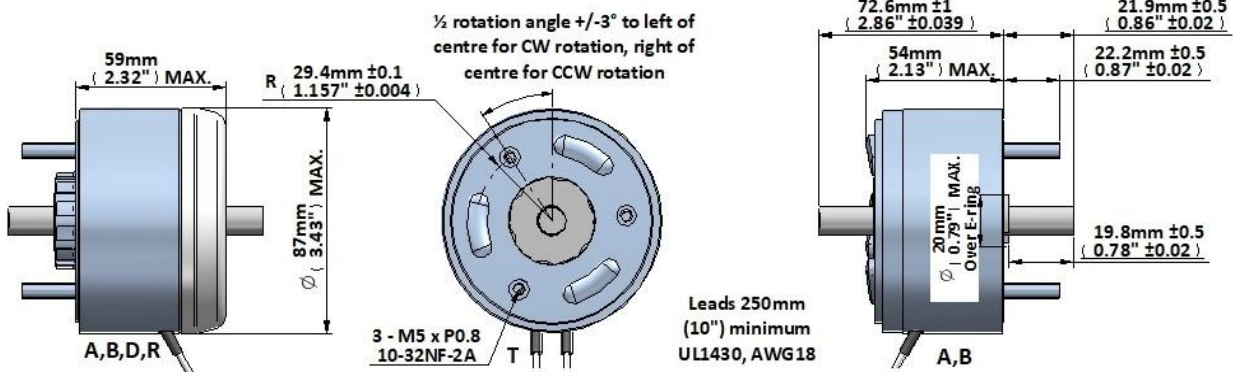
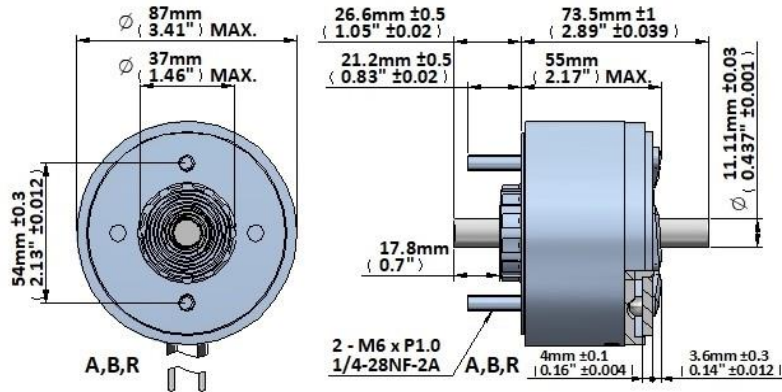

Data at 20°C, device connected to heatsink 520x520x3mm aluminum return spring 90 ~ 140 mNm

duty cycle = $\frac{\text{"on" time}}{\text{"on" time} + \text{"off" time}} \times 100\%$		100% cont.	75% or less	50% or less	25% or less	10% or less	
Max. "on" time in seconds		∞	85	72	43	20	
watts at 20°C		41	54.5	82	164	410	
ampere-turns at 20°		1910	2190	2750	3810	5950	
Gross starting torque at 20°C (Nm)		25°	1.84	2.65	4.25	6.9	11.300
		35°	1.38	1.84	2.76	4.5	7.35
		45°	1.15	1.5	2.2	3.9	6.2
		67,5°	0.48	0.69	1.15	1.95	3.34
		95°	0.4	0.48	0.7	1.15	1.95
AWG no.	resistance $\Omega \pm 10\%$ (at 20°C)	number of turns	volts DC				
18	1.47	368	7.6	8.7	11	15.0	24.0
19	2.3	459	9.6	11	14	19.0	30.0
20	3.64	580	12	14	17.0	24.0	37.0
21	5.57	704	15	17	22	30	47
22	9.5	936	19	22	28	39	30
23	14.3	1134	24	28	35	48	75
24	23.3	1456	30	35	44	61	95
25	37.1	1836	39	44	56	77	120
26	58.6	2300	49	56	70	97	152
27	89.8	2816	61	70	88	121	189
28	139	3456	76	88	111	153	239
29	227	4480	98	111	138	193	300
30	376	5792	124	143	177	248	387
31	515	6600	148	170	212	297	-
32	785	7850	188	220	275	385	-
33	1130	9050	237	271	339	-	-

Insulation Resistance >100MΩ, 500VDC Megger

Dielectric Strength 1000VAC, 50/60Hz, 1 minute

Class E (120°C) insulation class

Geeplus reserves the right to change specifications without notice

[www.geeplus.com](http://www.geeplus.com)



**GEEPLUS**

# Rotary Solenoid size 874

Device drawn in de-energised condition  
 Life Expectancy (cycles): >2M (-R),  
 >10M (-RE), >50M (-RL)

Available angle options:  
 25°, 35°, 45°, 67,5°, 95° (CW/CCW)  
 Mass 3056 grammes

Available mechanical options:

- A: shaft extension(armature side)
- B: shaft extension (base side)
- D: dust cover over the armature
- R: return spring
- T: tapped holes in armature plate

**Note.**

Screws should **NOT** pass the bottom of the armature plate.

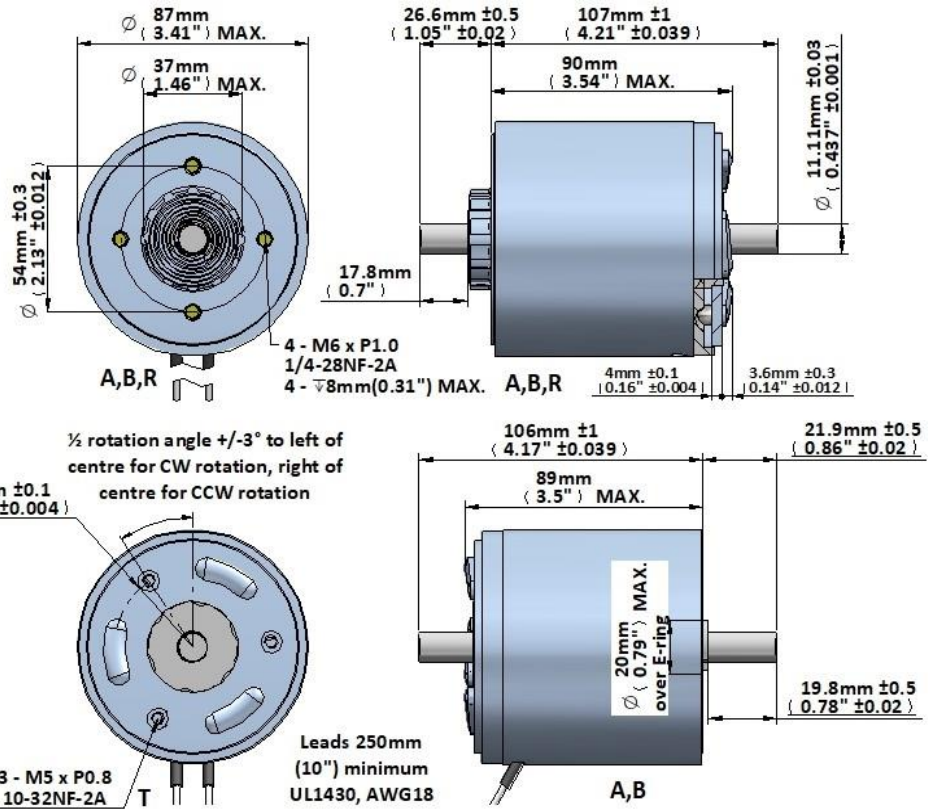

Data at 20°C, device connected to heatsink 520x520x3mm aluminum return spring 190 ~ 140 mNm

duty cycle = $\frac{\text{"on" time}}{\text{"on" time} + \text{"off" time}} \times 100\%$		100% cont.	75% or less	50% or less	25% or less	10% or less	
Max. "on" time in seconds		∞	85	72	43	20	
watts at 20°C		41	54.5	82	164	410	
ampere-turns at 20°		2590	2990	3663	5180	8190	
Gross starting torque at 20°C (Nm)		25°	3.6	4.7	6.5	10	13
		35°	2.4	3.1	4.2	6.4	8.7
		45°	2.0	2.6	3.6	5.5	7.4
		67,5°	1.0	1.3	1.8	2.9	3.9
		95°	0.66	0.82	1.1	1.7	2.2
AWG no.	resistance	number of turns	volts DC				
	$\Omega \pm 10\%$ (at 20°C)		10	12	15	21	33
18	2.54	630	10	12	15	21	33
19	4.15	828	13	15	18	26	41
20	6.38	1047	16	18	22	32	50
21	11.14	1408	20	24	29	41	65
22	16.8	1723	25	29	36	51	80
23	25.8	2046	33	38	46	65	103
24	42.5	2711	41	47	57	81	128
25	66.3	3279	52	60	74	105	166
26	105	4151	66	76	93	131	207
27	165	5190	82	95	116	165	260
28	261	6500	104	120	147	208	329
29	422	8340	131	151	185	262	-
30	664	10230	168	194	238	336	-
31	968	12410	202	233	286	-	-
32	1520	15200	259	299	366	-	-

Insulation Resistance >100MΩ, 500VDC Megger

Dielectric Strength 1000VAC, 50/60Hz, 1 minute

Class E (120°C) insulation class

Geepus reserves the right to change specifications without notice

[www.geepus.com](http://www.geepus.com)