

Brushless DC Motors with Integral Drive

KinetiMax 24 EB Series

24 mm diameter, 6 mNm max. torque, up to 2.7 W output power

The KinetiMax 24 EB is an extremely compact brushless DC motor with integrated drive electronics. This motor is an outer-rotor motor with a robust bearing system capable of handling high side loads.

The KinetiMax 24 EB employs an external rotor and iron core stator to maximize torque production.

High quality components ensure a minimum operating life of 20,000 hours. The KinetiMax 24 EB is a good choice for many types of small pumps, laser scanners, small high performance fans, blowers and medical equipment.

Options & Accessories

- Customized shaft
- Customized mounting flange
- Custom leads and connector configurations
- Special winding configurations
- Gearbox



Features & Benefits

- Outer-rotor, precision 24 mm diameter brushless DC motors with integrated drive electronics
- Rated up to 2.7W power output at 4300 RPM nominal speed
- 6, 12 or 24 VDC winding choice
- 2-wire version is as simple to control as a DC motor, needing only a DC voltage to operate
- Protection against voltage reversal
- Low EMI – complies with EN 55014-1/2, 61000-6-1/3
- IP30 level protection sealing
- 5-wire speed control version
- Integrated electronics with control input
- Tachometer output (18 pulses per rev) for speed monitoring
- Input to enable direction reversal

QuickShip Products

Some of the part number configurations for this product are in stock and available for ***immediate delivery!***

Look for the QuickShip symbol next to available part numbers. Then, click on the part number to go directly to our online store.



KinetiMax 24 EB – Specifications

Model	2-wire CW Rotation	KMX-01621492	KMX-01621512	KMX-01621532
	2-Wire CCW Rotation	KMX-01621502	KMX-01621522	KMX-01621542
	5-Wire	KMX-01621513	 KMX-01621523	KMX-01621533
Voltage VDC	Nominal	6	12	24
	Range ¹	5.5 – 9	7 – 17	10 – 28
Rated Output Power	W	2.2	2.7	2.7
Torque mNm (oz.in.)	Rated	5 (0.70)	6 (0.85)	6 (0.85)
	Max	7 (0.99)	9 (1.27)	9 (1.27)
Torque Constant	mNm/A (oz.in./A)	7.6 (1.07)	15.7 (2.16)	31.4 (4.45)
Speed RPM	Rated	4200	4250	4300
	No-load	7150	7050	7070
Current mA	Rated	750	445	230
	Max	950	630	330
	No-load	105	62	40
Rotor Inertia	kgm ² (oz.in.s ²)	0.77 E-6 (1.09 E-4)		
Mechanical Time Constant	ms	47	35	35
Thermal Resistance °C/W	Housing-Ambient	25.5		
Weight	g (oz)	30 (1.06)		
Protection Level		IP30		
Control Input ² V	Range	0 - 5		
	Threshold	1		
Direction Input V	CW	High ≥3.5		
	CCW	Low ≤1.5		
Speed Output Signal ²	PPR	18		
Operating Temperature Range	°C (°F)	0 – 90 (32 – 194)		
Thermal Limit Protection	°C	N/A (Maintain maximum motor housing temperature ≤ 90 °C)		

Values valid for nominal voltage and Tamb = 22 °C

¹ Power supply provided with appropriate 68 µF buffer capacitor between supply voltage and common to comply with EN 55014-1/2

² Applicable for 5 wire versions only

KinetiMax 24 EB – Performance

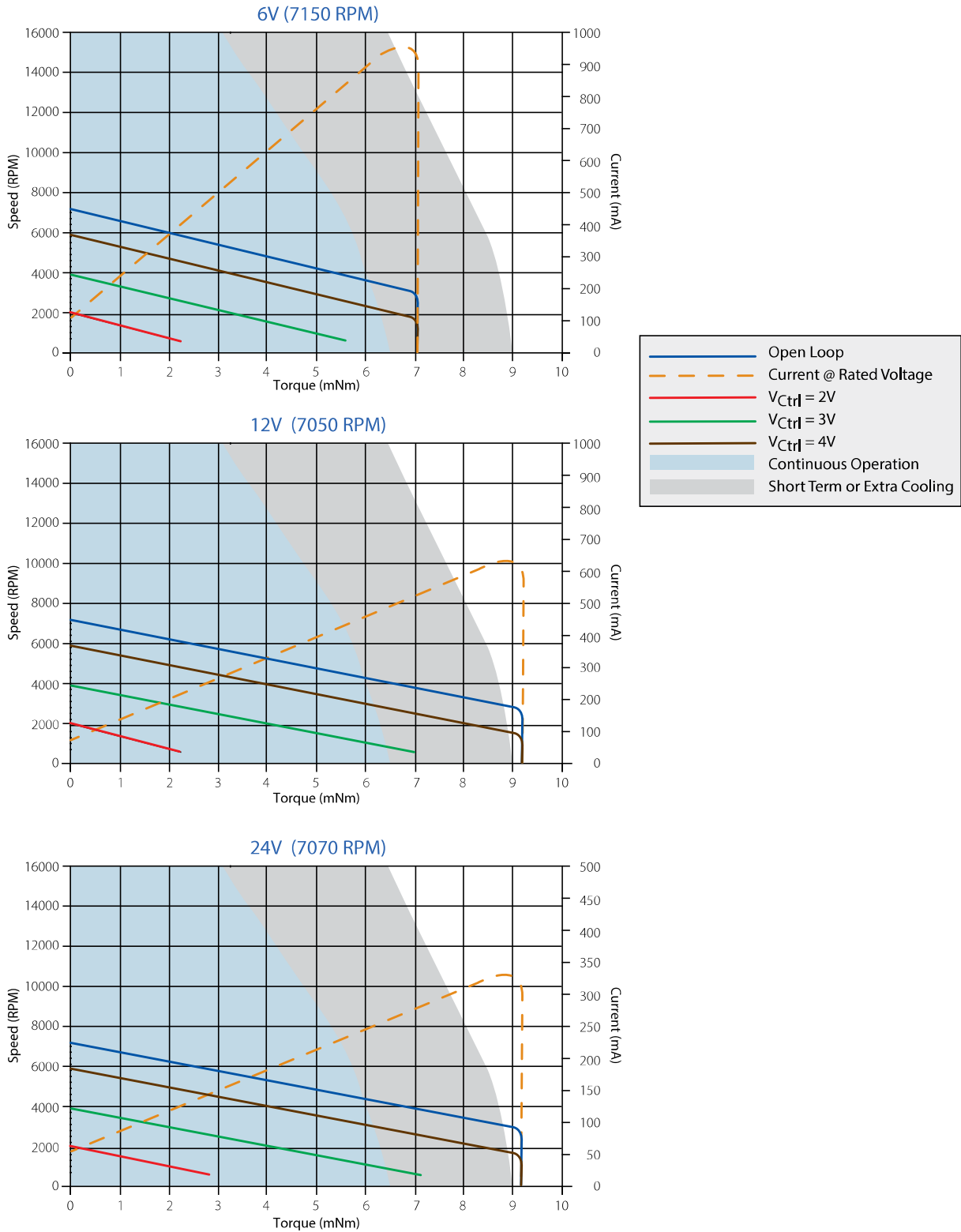

KinetiMax 24 EB – I/O Schematics

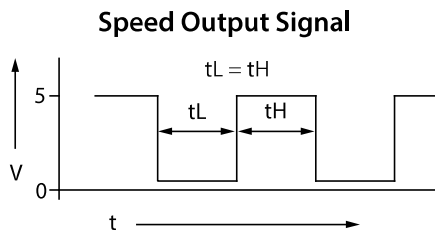
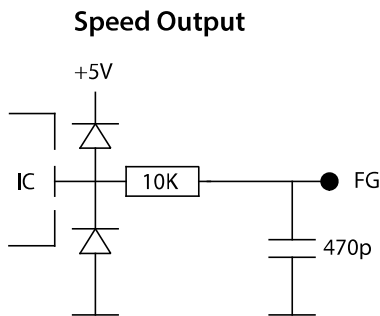
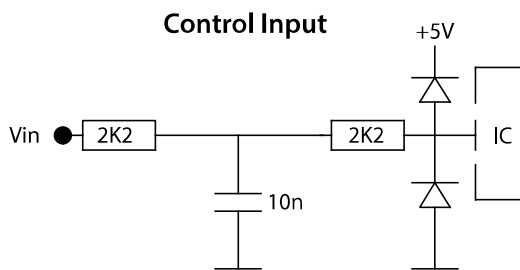
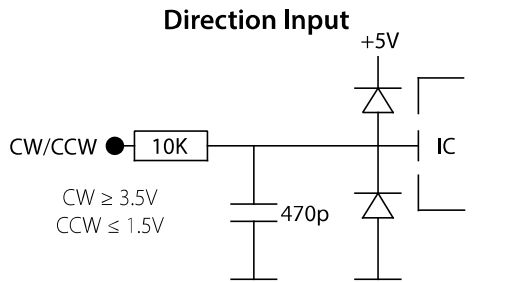

EMC

To meet EMC directive EN 55014, the power supply must be provided with a capacitor 68 μ F, 35V at the output:

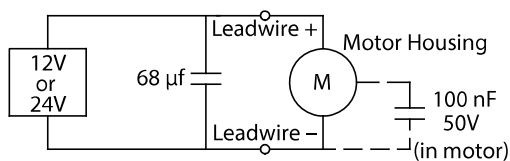

KinetiMax 24 EB – Electrical Connections

Version	Description	Wire Color (AWG 26)
2-Wire (CW & CCW)	Supply Voltage (+Vs)	Red
	Common (GND, ground)	Blue
5-Wire	Supply Voltage (+Vs)	Red
	Common (GND, ground)	Blue
	Control input (V_{Ctrl} , V)	White
	Speed output (Tach, FG)	Green
	Direction input (CW/CCW)	Brown

KinetiMax 24 EB Dimensions — mm (in)

